

MINIMUM SPECIFICATION FOR MANURE PITS AND DUNGSTEADS

The receiving of this specification does not imply approval of a grant application. However, if written approval is issued, then this specification becomes part of the contract between the applicant and the Department of Agriculture and Food.

This is a minimum specification. Where the word “SHALL” is used, then that standard (at least) must be followed in grant-aided buildings. Where a procedure is “RECOMMENDED”, this is advice only on good practice.

Note that all references to other Department Specifications are to the current edition of that specification [available on the Department of Agriculture and Food Website (www.agriculture.gov.ie) under Farm buildings]. Similarly, references to Standards are to the current edition of the Irish, British or European Standard, as appropriate.

This specification is arranged as follows:

A	GENERAL	2
A.1	General	2
A.2	Safety	2
A.3	Concrete Specification	3
A.4	Siting of Manure Pits and Dungsteads	4
B	MANURE PIT	4
B.1	Foundation of Manure Pit Floor and Channel	4
B.2	Foundations for Manure Pit Walls	5
B.3	Steel Reinforcement	5
B.4	Placing of Concrete	6
B.5	Precast Wall	6
B.6	Thickness of Concrete Floor Slab	7
B.7	Concrete to Floor Slab	7
B.8	Channels	7
B.9	Roofing of Manure Pits	8
C	DUNGSTEADS	11
C.1	Safety	11
C.2	Foundation of Dungstead Floor	11
C.3	Foundations for steel uprights	11
C.4	Uprights	11
C.5	Walls	12
C.6	Floor	12
C.7	Ramp	13
C.8	Effluent Tank	13

A GENERAL

A.1 General

A **MANURE PIT** is a leak-proof structure for the storage of a range of organic wastes such as manure produced in bedded animal housing, and discarded fodder. Uncovered pits shall have a front channel to collect contaminated rainfall and seepage. The channel shall be connected by a leak-proof pipe to a storage facility whose capacity is specified in accordance with S.I. 378 of 2006 Regulations, European Communities (Good Agricultural Practice for Protection of Waters). A manure pit without walls may be constructed as long as channels are provided all round the base.

A **DUNGSTEAD** is a structure for the storage of slurry produced from non-bedded cattle houses where provision is made for the liquid portion of the slurry to seep out through perforated walls for collection in a leak-proof storage tank. **Silage effluent shall not be allowed to flow into a dungstead.**

Note: Dungsteads are not a grant-aided item under the Farm Improvement Scheme launched in July 2007. As dungsteads were grant-aided under the FWM scheme, they are described in this Specification. However, they now have no useful place on most farms, being very expensive, labour intensive and inefficient. For reasons of pollution control, the tanks for the liquid and rainfall from a dungstead are now required to be sized for 16, 18, 20 or 22 weeks storage as required in S.I. 378 of 2006 Regulations. In almost all cases, a reinforced concrete slurry store, or other approved slurry store, will be a more efficient and cheaper solution. Dungsteads may be of use on farms with very low animal numbers in areas of low rainfall.

A.2 Safety

A.2.1 Responsibility for Safety

Applicants are reminded that they have a duty under the Safety, Health, and Welfare at Work Act 2005 to provide a safe working environment on the farm, including farm buildings, for all people who may work on that farm. There is a further duty to ensure that any contractor, or person hired to do building work, provides and/or works in a safe environment during construction.

A.2.2 Safety during Construction

Farmer/Applicant Responsibility: Please note that neither the Minister nor any official of the Department shall be in any way liable for any damage, loss or injury to persons, animals or property in the event of any occurrence related to the development and the applicant shall fully indemnify the Minister or any official of the Minister in relation to any such damage, loss or injury howsoever occurring during the development works.

Dangers: Where the applicant/farmer is undertaking any part of the above work, it is his/her responsibility to seek competent advice and to undertake all temporary work required to ensure the stability of excavations, superstructure, stanchion foundations, wall foundations, to guard against possible wind damage and to avoid any other

foreseeable risk. It is also his/her responsibility to ensure that any drains, springs or surface water are diverted away from the works.

Power lines: Farm buildings shall not be constructed under or nearer than 10m to an overhead power supply. If advice is required, or if power lines need to be diverted, it is the applicant's responsibility to contact, in writing, the local ESB supervisor before construction commences and then to follow the ESB conditions.

Danger to children: It is the applicant's responsibility to prevent children from playing or spending time in the vicinity of any construction work.

A.3 Concrete Specification

A.3.1 Certificates

Concrete shall be produced in an audited plant only: It shall not be produced on site. A numbered certificate, signed and stamped, shall be required for all concrete delivered to site. The certificate, the "Concrete Manufacturers' Specification Certificate", is produced in triplicate. The top certificate, printed on light blue paper, shall be retained by the applicant and given to and retained by the local AES Office of the Department of Agriculture for inspection upon completion of the works.

A.3.2 Concrete

For all manure pits and dungsteads, concrete shall be purchased on the basis of a characteristic 28 day crushing strength of 35N/mm². Minimum cement content shall be 300 kg/m³. Slump of unplasticised concrete shall not exceed 90mm, and maximum aggregate size shall be 20mm.

The concrete shall be ordered by requesting '35N concrete to be certified to the grant-aid standard of the Department of Agriculture and Food'.

If the Concrete Supplier requires further information the following shall be quoted to them:

- The concrete is to be to I.S. EN 206-1:2002: Strength Class: C28/35, 300 kg cement, maximum water cement ratio of 0.60, Exposure classes: XC4, XF3, XA1 (20 year life), Slump class: S2 (unplasticised), maximum aggregate size 20mm.

If plasticised concrete is desired, the slump class shall not exceed S3.

Polypropylene fibres may be incorporated into the concrete mix to improve the properties of concrete. Only fibres, which have been tested and approved by National, or European approval authorities, may be used. The use of fibres helps to reduce plastic cracking and improve surface durability but they are not a substitute for structural reinforcement. Fibres shall be used in strict compliance with manufacturer's instructions and shall only be added at the concrete manufacturing plant. The concrete certificate (Clause A.3.1) shall clearly show the amount and type of fibre added. The mix design, compacting, and curing of fibre concrete is the same as concrete without fibre.

A.3.3 Materials

Cement used in concrete and concrete products shall be certified to IS EN 197-1, and shall bear the Irish Standard Mark, or shall be certified by NSAI to be equivalent to IS

EN 197-1. All aggregates shall be to IS 5 1990. Plasticisers and other admixtures shall be to EN 934. All admixtures shall be used in strict accordance with manufacturer's instructions, and shall be added only by the concrete-mix manufacturer.

A.3.4 Tests

The Department reserves the right to require that concrete should be tested in accordance with BS1881, and that installed reinforcement may be checked by electronic or other means.

A.3.5 Compaction of Concrete

All concrete shall be compacted by either vibrating screed or poker vibrator depending upon the position of the concrete. Poor compaction leads to entrapped air, which will weaken the concrete and may cause premature failure. All concrete can be easily placed and compacted when using a vibrating screed or poker vibrator which helps ensure the concrete achieves its full strength.

A.3.6 Curing of Concrete

All concrete shall be cured by keeping it thoroughly moist for at least seven days. Wetted floor slabs and walls shall be protected by polythene sheeting, kept securely in place. Alternatively proprietary curing agents may be used in accordance with manufacturer's instructions. When frost is a danger, straw bales shall be placed over the polythene on slabs. Concrete shall be at least 28 days old before being subjected to full load.

A.4 Siting of Manure Pits and Dungsteads

The site shall be carefully chosen with a view to minimising operational and constructional problems. As a general guide, a storage facility for manure or dung should be located not less than 50m from any waterbody in the case of new farmyards, and not less than 10m in the case of extensions/modifications to an existing facility. The minimum distance between a storage facility and a public/private water supply source, either surface or ground, shall be 60m. In vulnerable situations this distance shall be increased up to 300m.

It is strongly recommended that a roofed manure pit is not constructed as part of a livestock house. Where a roofed manure pit is constructed as part of a livestock house, then it shall be designed such that the animals cannot have direct contact with the manure. This requires that a wall, minimum 1.8m high, shall be constructed around the manure pit so that the only method of accessing the manure pit is from outside the building.

B MANURE PIT

B.1 Foundation of Manure Pit Floor and Channel

All topsoil and soft material shall be excavated to a minimum depth of 150mm, or down to solid stratum, and the excavated material shall be removed from site to a suitable area. The foundation shall consist of thoroughly compacted hardcore and shall extend to a minimum of 300mm in each direction beyond the edge of the finished floor. Hardcore placed in excavated soft areas or on made-up ground shall be

compacted in max. 150mm layers using a suitable vibrating or heavy roller. Consolidation with wheeled or tracked plant is not adequate. The depth of compacted hardcore shall not be less than 150mm at any point. Special care shall be exercised in compacting the edges of the slab, and under proposed channels. Where channels are constructed the level of the foundation shall be lowered in accordance with Figs. 5, 6 & 7. All hardcores shall be blinded over by fine sand or a 50mm layer of blinding concrete finished smooth. The hardcore base shall be finished to a minimum fall of 1:40 when no walls are to be constructed.

B.2 Foundations for Manure Pit Walls

Foundations for manure pit wall footings shall be excavated to a minimum depth of 600mm below the original ground level, or to such further depth necessary to reach firm strata to ensure stability of structure. The excavation shall be taken out neatly so as to produce clean-cut, vertical sides against which concrete for the footings shall be poured. On completion of the excavation a 50mm (min) layer of blinding concrete shall be placed on the bottom of the excavation.

B.3 Steel Reinforcement

All manure pit walls, other than kerbs, shall be reinforced as described below. Walls shall not exceed 1.8m in height. For walls greater than 1.8m high, the walls shall be constructed as per S.120, or shall be designed by a Chartered Engineer.

B.3.1 Steel Reinforcement Bars

These shall consist of high yield steel with ribbed finish in accordance with the current edition of BS 4661. All steel shall be free from mill scale, and heavy deposits of rust. Steel bars shall not be straightened and rebent. Where bars must be overlapped, the overlap shall be at least 40 times the bar diameter.

B.3.2 Bending and Fixing of Steel

Steel bars shall be cut and bent as per Fig. 2. The minimum cover of 50mm shall be achieved and maintained by the use of proprietary fixing blocks or space wheels. Junctions of bars shall be securely tied with 16 SWG tying wire (1.6mm diameter) or by tack-welding to ensure that steel is kept firmly in position during concreting.

B.3.3 Steel Reinforcing in Walls

All steel shall be 10mm diameter. Vertical steel shall be placed at 225mm centres and shall extend to within at least 475mm of the top of the wall. Horizontal steel shall be placed at a maximum of 400mm centres and shall start at a maximum height of 460mm. The top horizontal bar shall be placed at the top of the vertical bars, and intermediate horizontal bars shall be spaced evenly between the top and bottom bars as shown on Fig. 3.

Horizontal steel to footing shall be at 500mm centres and sized as shown in Fig. 2.

At each rear corner a vertical bar shall be placed with its foot on the diagonal as shown on Fig. 4. This bar and the 3 bars on each side shall be extended to within 50mm of the top of the wall. Close to the top of the wall one horizontal L bar, min. 800mm each leg, shall be tied to the vertical steel.

B.4 Placing of Concrete

B.4.1 Shuttering

Steel shuttering is recommended for manure pit walls but panels lined with timber may be used. All shutterings must be clean and tight fitting to prevent loss of grout. To maintain cleanliness and facilitate removal they should be oiled lightly with proprietary mould oil prior to each use. Care must be taken that oil does not get onto reinforcing bars and prevent bonding. All shutterings must be properly tied and braced to withstand the pressure of the concrete.

B.4.2 Footings

Reinforcing shall be placed as set out in Clause B3. Concrete shall be poured to complete a footing in a single day. Vibration, by poker vibrator of diameter not less than 50mm shall follow closely on placing. The poker shall be inserted at maximum 400mm centres.

B.4.3 Pouring Concrete to Manure Pit Walls

All dirt and debris shall be removed from within the shuttering. Concrete shall be placed in evenly spread layers of not more than 600mm deep. Vibration, by poker vibrator of diameter not less than 50mm shall follow closely on placing. The poker shall be inserted at maximum 400mm centres. It shall be allowed sink under its own weight to the depth of the layer plus 100mm into the layer beneath and when air bubbles cease to rise, be withdrawn slowly but evenly leaving no significant depression in the concrete. Care shall be taken to prevent the vibrator making contact with either the shutters or the reinforcement. Concrete shall not be poured under 4⁰C in a falling thermometer.

B.4.4 Removal of Shuttering

Shuttering shall not be removed for at least 12 hours in warm weather, longer in cold weather. Fill all small blemishes caused by removal of bolts and tie bars with 1.5:1 washed sharp sand-cement mortar. All large bolt or tie bar blemishes and honeycombing, if they occur, shall be repaired with a sand: cement mortar incorporating SBR (Styrene Butadine Rubber) or a water resistant polymer bonding admixture in accordance with manufacturer's instructions.

Note: If good shuttering, properly erected, is used and concrete of proper workability has been well compacted, honeycombing should not occur.

B.5 Precast Wall

Precast wall systems are acceptable provided such walls are constructed in accordance with Department of Agriculture and Food requirements. They shall require prior Departmental acceptance, and may be subject to requirements for certificates of guarantee. Moveable wall panels are not permitted. All precast walls shall be permanently fixed in place, in the manner specified by the Specialist Unit of the Department of Agriculture and Food for the particular wall panel being used.

Foundations shall be constructed in strict accordance with manufacturers instructions. Standard effluent channels shall be constructed outside the walls in all cases. Joints between panels shall be sealed with acid resistant mastic in accordance with manufacturers instructions.

B.6 Thickness of Concrete Floor Slab

The thickness of the concrete slab shall be as shown on the detailed drawing but at no place shall it be less than 125mm. Under channels the concrete shall be thickened to at least 150mm below the invert level of the channels as shown (Figs. 5, 6 & 7).

B.7 Concrete to Floor Slab

A 1000 gauge polythene membrane shall be laid on the finished hardcore with 600mm overlaps. The overlaps shall be sealed with suitable adhesive tape. The polythene shall be brought up on the inside of the timber or steel formers. The edges of the slabs (except where the slab abuts an existing bay) shall be supported by strong shuttering, set to the correct level. Concrete shall be laid in alternate bays measuring not more than 4.5m wide by 6m long where there is no fibre additive and not more than 4.5m wide by 8m long with fibre additive. Concrete should be allowed to harden for at least 2 days before the remaining bays are poured. The edges of the slabs (except where the slab abuts an existing bay or silo wall) shall be supported by strong shuttering, set to the correct level. The concrete should be placed about 20mm proud of the shuttering and then tamped down to the correct level using a vibrating screed. Particular care should be taken to compact the concrete near edges and joints, preferably with a poker vibrator.

Joints between alternate bays should have a 25mm x 12mm recess preformed by the shuttering. This joint to be brushed out and filled with acid resistant mastic sealant. Alternatively, where concrete base is laid in one operation, joints (in bays not exceeding 4.5m wide by 6m long without fibre additive or 4.5m wide by 8m long with fibre additive) shall be cut by disc-cutter to a depth of 30mm and to a full 12mm width formed by a double cut in the hardened concrete within 24 hours of placing. These joints shall be brushed out and filled when dry with acid resistant mastic sealant installed in strict compliance with the manufacturer's instructions. Extra care shall be taken that joints running across effluent channels are completely sealed. The junction of floor and wall shall be treated as a joint.

If it is thought necessary to strengthen the slab for any reason, A 142 steel mesh may be installed 50mm above the bottom of the slab. In all cases construction joints shall be formed.

B.8 Channels

Manure pits without walls shall have channels at the back, sides and front to collect and convey all the effluent and soiled water that results from the use of the pit to a leak-proof storage tank. Side and back channels shall be set at least 200mm in from the edge of the concrete base. This 200mm concrete verge shall have a fall towards the channel as shown in Fig. 7. The front of the manure base shall have a recessed channel to convey the effluent to the approved storage facility. Side and back channels shall be constructed as shown in either Fig. 7 or Fig. 8. Front channels shall be constructed as shown in either Fig. 5 or Fig. 6. Care shall be taken when forming the channel to ensure that adequate depth and fall is maintained during construction and that sufficient concrete is provided at the sides and under the invert of channel as shown.

Where surface water from concrete yards or other surrounding areas is likely to gain access to the manure base, a kerb type channel as per Fig. 8 shall be constructed to the back and sides.

Effluent shall be piped in 100mm uPVC pipe preferably through an interception chamber with a silt trap to a storage tank.

B.9 Roofing of Manure Pits

The roof for a manure pit shall be constructed to the current edition of Specification S101: Minimum Specifications for the Structure of Agricultural Buildings. The slope of the roof shall be as for a livestock house. The roof shall incorporate an overhang of 0.5m on all sides so as to reduce entry of rainfall. The overhang at the gable may be achieved by cantilevering the purlins in the end bay by 0.5m beyond the gable rafter/truss. An unobstructed outlet of at least 300mm shall be provided at the highest point of the roof. All electrical work including lighting shall be to ETCI standards.

Side and end cladding is not permitted, however, the installation of 'chicken wire' mesh is permitted in place of side cladding. The minimum distance between the top of any wall present and the eave of the building shall be 1.5m.

Where a walled manure pit is envisaged, the wall may be constructed between the stanchions, alternatively, the stanchions may be erected outside the wall. Under no circumstances shall the erection of stanchions on top of the walls be permitted.

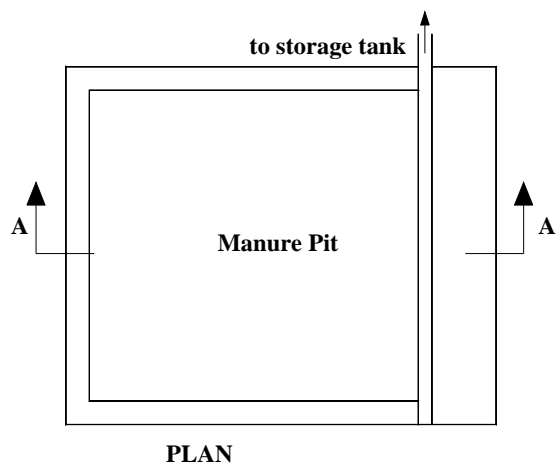

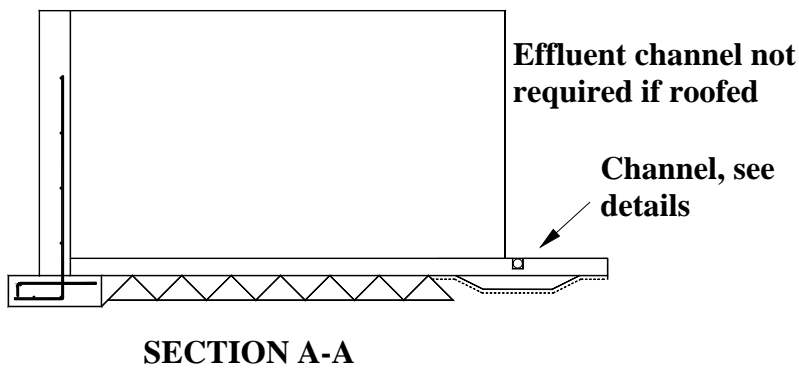

Figure 1 Plan and Elevation of Manure Pit

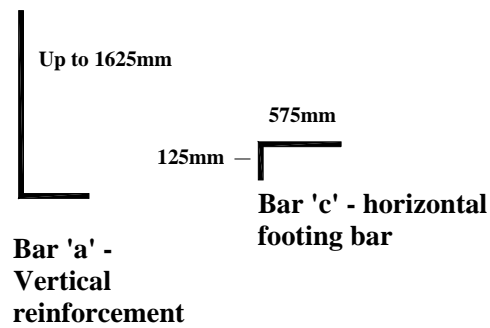

Figure 2 Steel Bar Detail

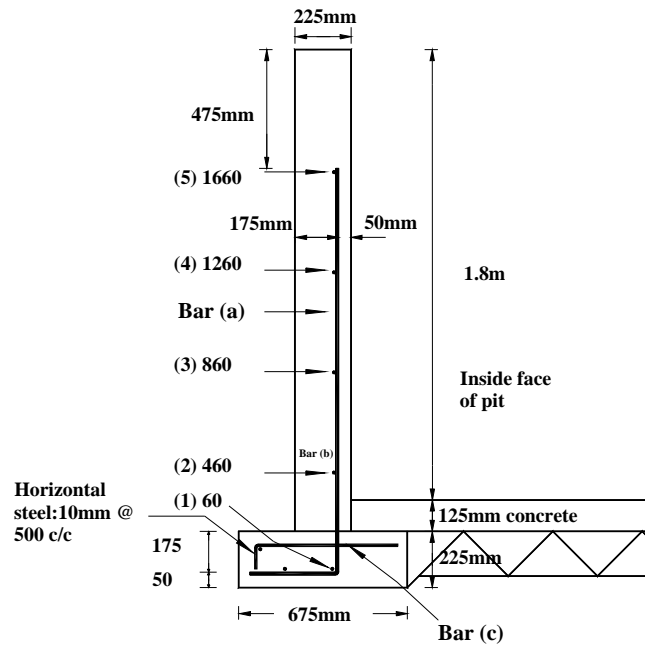

Figure 3 Wall Reinforcement

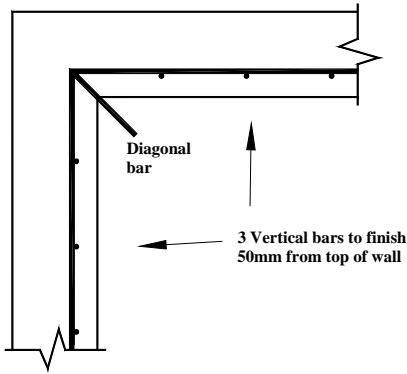

Figure 4 Steel Arrangement at Wall Corners

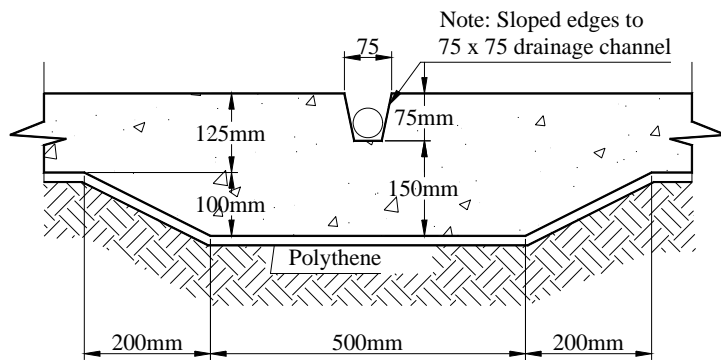

Figure 5 Front-Channel /Cross-Channel

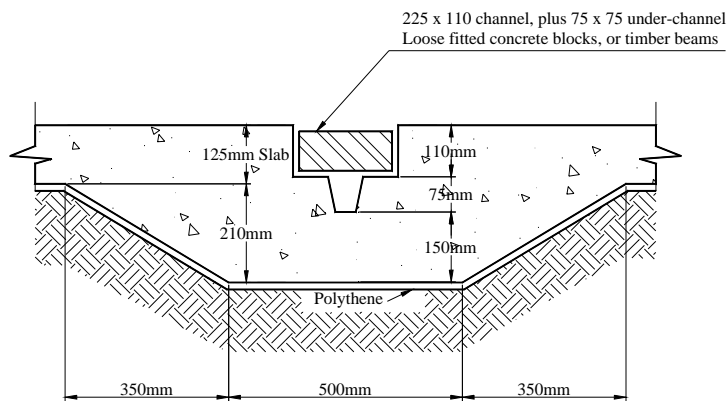

Figure 6 Alternative Front-Channel

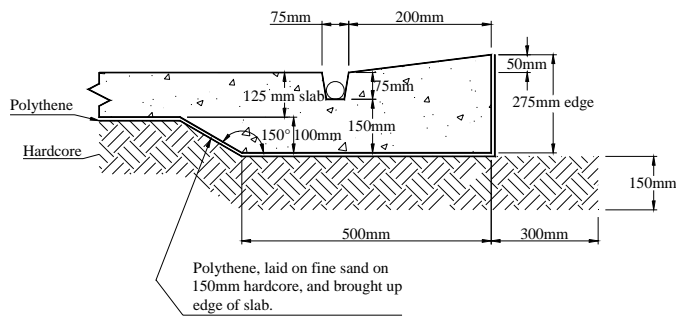

Figure 7 Side-Edge or Back-Edge (Standard)

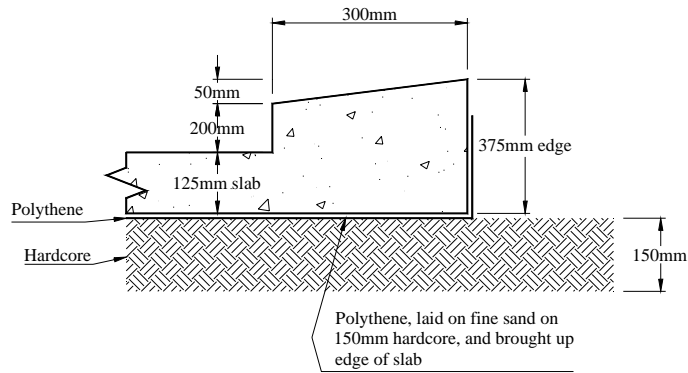

Figure 8 Side-Edge / Back-Edge (Kerb-Type)

C DUNGSTEADS

C.1 Safety

Where slurry is pushed into the dungstead either by ramp, or directly where levels permit, a barrier shall be provided at the point of entry. In the case of a ramp this shall be by way of strong barrier as indicated in Fig. 9. In the case of direct entry this shall be by way of ope in 225mm solid concrete wall.

C.2 Foundation of Dungstead Floor

All topsoil and soft material shall be excavated to a minimum depth of 150mm, or down to solid stratum, and the excavated material shall be removed from site to a suitable area. The foundation shall consist of thoroughly compacted hardcore and shall extend to a minimum of 300mm in each direction beyond the edge of the finished dungstead. Hardcore placed in excavated soft areas or on made-up ground shall be compacted in max. 150mm layers using a suitable vibrating or heavy roller. The depth of compacted hardcore shall not be less than 150mm at any point. Special care shall be exercised in compacting the edges of the slab, and under proposed channels. Where channels are constructed the level of the foundation shall be lowered in accordance with Figs. 11. All hardcores shall be blinded over by fine sand or a 50mm layer of blinding concrete finished smooth.

C.3 Foundations for steel uprights

Excavate neatly to provide for a concrete base for steel uprights, 600mm square by 600mm deep for short spans (less than 2.7m), and 600mm square by 650mm deep for long spans (more than 2.7m). The top of the base shall finish flush with the underside of the floor slab.

Foundations for the steel uprights shall be excavated to a minimum depth of 600mm below the original ground level, or to such further depth necessary to reach firm strata to ensure stability of structure. The excavation shall be taken out neatly so as to produce clean-cut, vertical sides against which concrete for the footings shall be poured.

C.4 Uprights

Steel uprights shall conform to BS 4 Part 1. The minimum size shall be 152mm x 89mm x 16kg where the spacing shall be 2.4m. The maximum spacing shall be 3.2m

in which case the uprights shall be 178 x 102mm x 19kg. Alternatively European Sections may be used as follows, minimum IPE 180's for a short span, and IPE 200's for maximum spacing.

Short span uprights shall be at least 2.3m long and long span uprights shall be at least 2.4m long. These shall extend at least 150mm above wall height.

C.5 Walls

The wall on the side from which the yard is scraped shall be of reinforced concrete as may one other wall. These walls shall be reinforced on the inside face with 10mm high yield steel bars: verticals at 250mm and horizontals at 460 centres. Steel shall be bent and anchored 300mm horizontally into the base of the foundation and have a minimum cover of 25mm. Every second vertical shall be to full wall height less 450mm. Every other vertical shall be to one fourth of wall height plus 300mm.

Where any wall or part of a wall is below yard level it shall be reinforced as above on both faces.

Maximum height of perforated walls shall be 1.4m constructed of timbers, minimum, 200 x 75mm for the bottom 600mm and a minimum of 150 x 75mm thick above that level. All timbers shall comply with IS recommendation SR11: 1988, marked SCA (Strength Class A) and pressure treated with preservative in accordance with current Irish Standard Specification. The gap between timbers may vary but shall never be less than 12mm. [First quality used timber railway sleepers may be used in the construction of perforated walls.] In order for the dungstead to operate efficiently, the bottom timber shall be supported at least 20mm above the floor either by a welded fillet of IPE section or other means.

Precast concrete panels are acceptable provided such panels are constructed in accordance with Department of Agriculture and Food requirements. They shall require prior Departmental acceptance, and may be subject to requirements for certificates of guarantee. All precast panels shall be permanently fixed in place, in the manner specified by the Specialist Unit of the Department of Agriculture and Food and shall be spaced as above.

Reinforced mass concrete walls may be constructed in place of the timber panels with steel uprights. The walls shall have min. 35mm diameter holes spaced at max. 200mm horizontal centres, and at 200mm vertical centres. The wall shall be reinforced as above. The first row of holes shall be spaced not more than 10mm above floor level. A panelled section, at least 2.1m wide, shall be constructed in at least one wall to enable emptying of the dungstead.

C.6 Floor

Lay 1000 gauge polythene membrane on finished hardcore with 600mm taped overlaps. The floor slab shall be 125mm concrete increased to 225mm for 1.2m wide strip at the outer edge of the base. The strip of concrete outside the walls shall contain a channel as shown in drawing. This shall be 100mm deep and not less than 225mm wide. Concrete shall be placed in alternate bays not more than 4.5m wide x 6m long where there is no fibre additive and not more than 8m long where there is fibre additive. Alternatively, where concrete base is laid in one operation, joints in bays not exceeding 4.5 x 6m shall be cut by concrete saw in hardened concrete within 24 hours

of pouring. All joints to be brushed out and filled with acid resistant mastic as per manufacturers instructions. Extra care shall be taken to ensure that joints running across effluent channels are completely sealed.

C.7 Ramp

Where space permits the ramp shall be external to the dungstead, terminating at the solid wall. It shall have a slope of not more than 1 in 8. It shall be constructed between two mass-concrete wing-walls tied into the main wall. Hardcore shall be placed between these walls and compacted as set out in clause C2. A 125mm concrete slab shall be laid on top of the hardcore to finish flush with the top of the main wall. The wing-walls should finish 225mm (minimum) above slab level to provide a safety kerb. The ramp width shall be not less than 2.1m clear between the kerbs. Where space is not available some or all of the ramp may be located within the dungstead area. In this case the main wall shall be returned maintaining its normal height to form access. The ramp shall then be constructed as before.

A stock proof and child proof fence, 1.8m high, shall be provided around the ramp.

Posts shall be 2.3m long minimum of either: -

- a) Reinforced concrete 125mm x 125mm at butt end (to IS 177: 1980)
- b) Galvanised angle iron 60mm x 60mm x 6mm thick
- c) Galvanised tubular steel, 75mm outside diameter, and 3.2mm thick

Uprights and strainers shall be embedded 400mm into 0.5m square concrete bases, not more than 3.0m apart. Four strands of 3.2 mm plain wire shall be strained, and stapled or tied to the uprights with tying wire. Chain link fencing, 2.5mm, (to IS 130:1980), 1.8m high, shall be secured to the outside of the line wires over entire fence. One strand of 2.5mm barbed wire shall be placed along the top of the fence.

A gate, the same width as the ramp, 1.8m high, of galvanised steel, or preservative treated timber, with closing bolts and locks, shall be fitted across the front of the ramp. The only horizontal bars shall be at the top and bottom of the gate. Chain-link fencing shall be fitted to the outside of the gate. The gate shall be designed such that neither people or stock can get through or under when closed.

Other proprietary fence systems will be acceptable if the above criteria are met.

When direct entry is used to fill the dungstead, a fence and suitably located gate, as describe above, shall be constructed along the entire length of the wall where the wall is less than 1.4m above ground level

C.8 Effluent Tank

A Reinforced concrete tank shall be constructed in accordance with S123. The tank shall be sized to retain at least 16 weeks effluent and rainfall, from the dungstead, for the duration of the housed period.

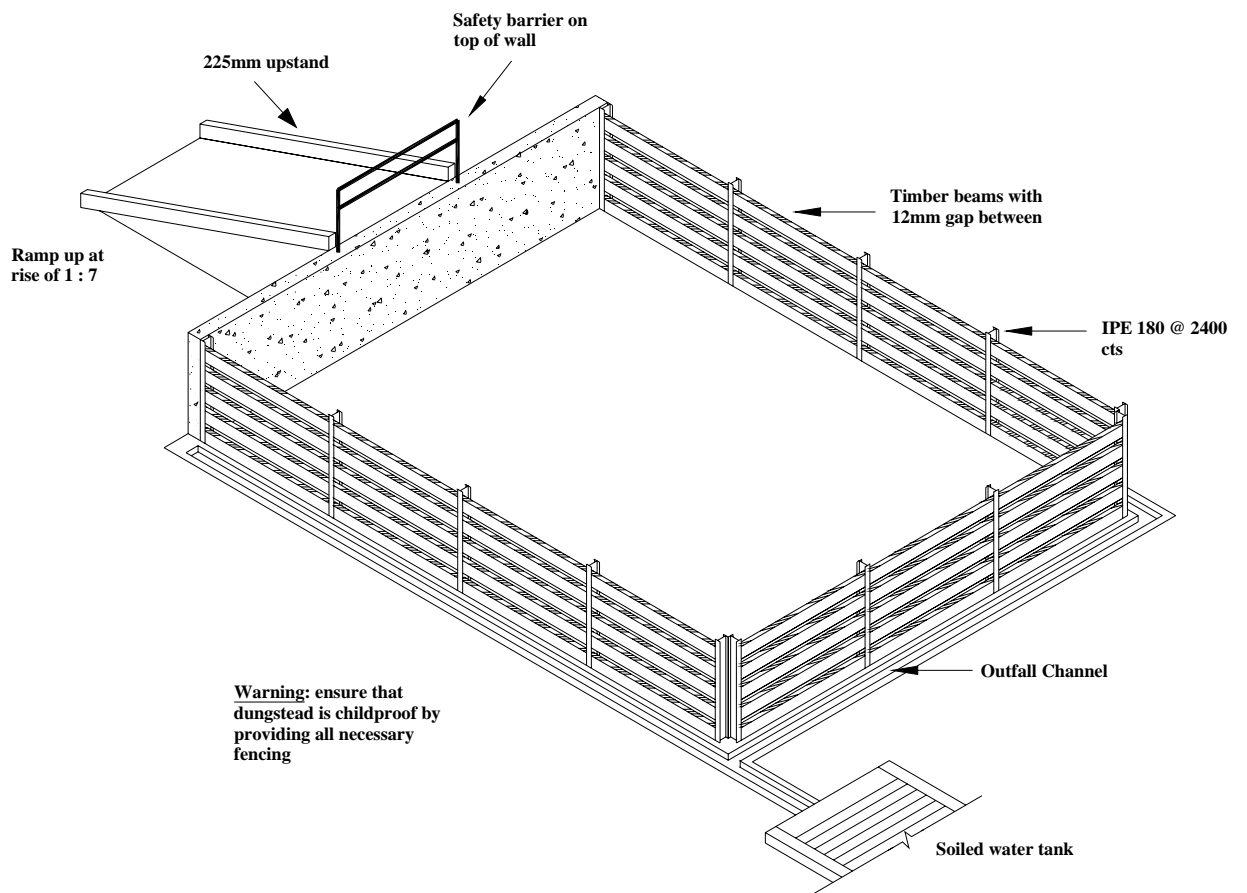

Figure 9 Dungstead

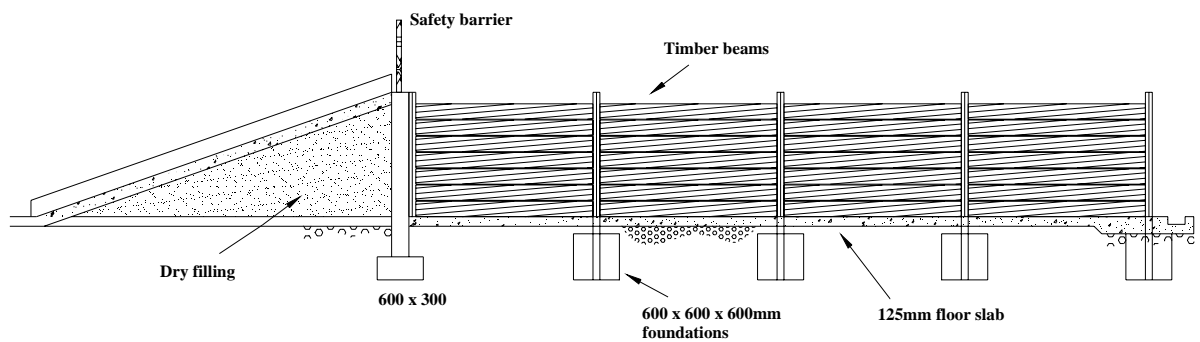

Figure 10 Elevation

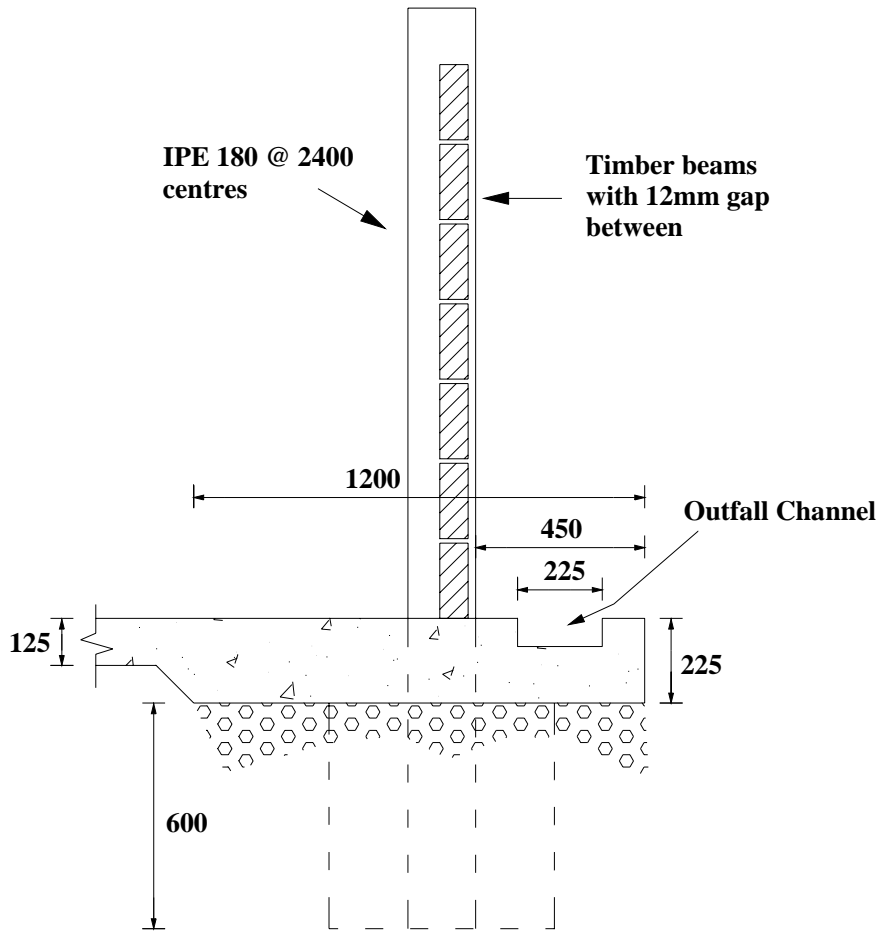

Figure 11 Section of perforated wall, channel and foundation

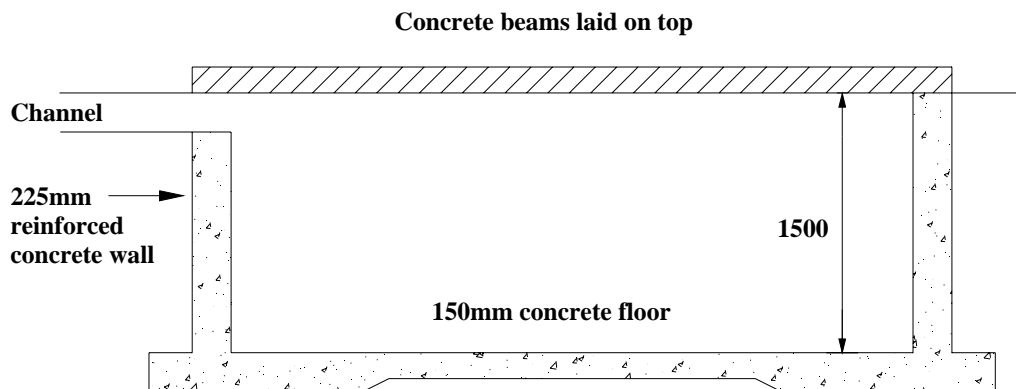

Figure 12 Soiled Water Tank and Sedimentation Chamber