

**AN ROINN TALMHAÍOCHTA AGUS BIA  
DEPARTMENT OF AGRICULTURE AND FOOD**

**MINIMUM SPECIFICATION FOR THE EXTENSION OF CONCRETE  
TANKS.**

**The receiving of this specification does not imply approval of a grant application.**

However, if written approval is issued, then this specification becomes part of the contract between the applicant and the Department of Agriculture and Food.

This is a minimum specification. Where the word “SHALL” is used, then that standard (at least) **must** be followed in grant-aided buildings. Where a procedure is “RECOMMENDED”, this is advice only on good practice.

Note that all references to other Department Specifications are to the current edition of that specification [available on the Department of Agriculture and Food Website ([www.agriculture.gov.ie](http://www.agriculture.gov.ie)) under Farm buildings]. Similarly, references to Standards are to the current edition of the Irish, British or European Standard, as appropriate.

This specification gives the full details of the preferred method for the extension of concrete slurry / effluent stores. **However, if other extension methods are to be used, then a full set of design drawings and full structural calculations shall be prepared by a Chartered Engineer, and given to this Department for prior approval before the start of construction.**

## **1 Safety**

### **1.1 Responsibility for Safety**

Applicants are reminded that they have a duty under the Safety, Health, and Welfare at Work Act 1989 to provide a safe working environment on the farm, including farm buildings, for all people who may work on that farm. There is a further duty to ensure that any contractor, or person hired to do building work, provides and/or works in a safe environment during construction.

### **1.2 Safety during Construction**

**Farmer/Applicant Responsibility:** Please note that neither the Minister nor any official of the Department shall be in any way liable for any damage, loss or injury to persons, animals or property in the event of any occurrence related to the development and the applicant shall fully indemnify the Minister or any official of the Minister in relation to any such damage, loss or injury howsoever occurring during the development works.

**Dangers:** Where the applicant/farmer is undertaking any part of the above work, it is his/her responsibility to seek competent advice and to undertake all temporary work required to ensure the stability of excavations, superstructure, stanchion foundations, wall foundations, to guard against possible wind damage and to avoid any other foreseeable risk. It is also his/her responsibility to ensure that any drains, springs or surface water are diverted away from the works.

**Power lines:** Farm buildings shall not be constructed under or nearer than 10m to an overhead power supply. If advice is required, or if power lines need to be diverted, it is the applicant's responsibility to contact, in writing, the local ESB supervisor before construction commences and then to follow the ESB conditions.

**Danger to children:** It is the applicants responsibility to prevent children from playing or spending time in the vicinity of any construction work.

### **1.3 Safety Notices**

It is recommended that at least one safety notice should be put on the side of a building next to which a slurry agitation point is situated. The notice should be as close to the agitation point as possible. [Notices are available from most farm supply outlets and Teagasc].

### **1.4 Toxic Gases and Agitation**

Harmful gases are generated in slurry stores and these have been responsible for both human and animal deaths. Good ventilation in slatted buildings is always important, and is vital during agitation or emptying of the tanks. Where silage effluent has been added to the slurry there can be a danger of more concentrated gases. Therefore:

1. Tanks shall always be agitated and/or emptied from the external agitation points, and never from openings within the house.
2. All doors, and any feed-flaps, shall be fully opened before agitation/emptying begins and kept open until completion of tank emptying.
3. No person shall enter the house during agitation or emptying. It is strongly recommended that animals be removed from the house before agitation. It is also recommended that animal holding pens are installed close to the house to facilitate this removal.
4. Some poisonous slurry gases are heavier than air. No person should climb down into an emptied or part-emptied tank without breathing apparatus. Such apparatus requires full training before it can be used.

### **1.5 Safety Tank Fencing**

A stock proof and child proof fence, 1.8m high, shall be provided around all external tanks not already protected by safety covers as specified in Clause 4.5 of S. 123.

Posts shall be 2.3m long minimum of either:-

- a) Reinforced concrete 125mm x 125mm at butt end (to IS 177: 1980)
- b) Galvanised angle iron 60mm x 60mm x 6mm thick
- c) Galvanised tubular steel, 75mm outside diameter, and 3.2mm thick

Uprights and strainers shall be embedded 400mm into the tank wall or in 0.5m square concrete base, not more than 3.0m apart. Alternatively they may be fixed to the outside of the tank with proprietary bolts to manufacturer's instructions. Four strands of 3.2 mm plain wire shall be strained, and stapled or tied to the uprights with tying wire. Chain link fencing, 2.5mm, (to IS 130:1980), 1.8m high, shall be secured to the outside of the line wires over entire fence. One strand of 2.5mm barbed wire shall be placed along the top of the fence.

A 3.5m wide gate, 1.8m high, of galvanised steel, or preservative treated timber, with closing bolts and locks, shall be fitted at each agitation or emptying point. The only horizontal bars shall be at the top and bottom of the gate. Chain-link fencing shall be fitted to the outside of the gate. The gate shall be designed such that neither people or stock can get through or under when closed. A safety concrete kerb, minimum 300mm x 600mm wide, shall be installed near the edge of the tank, across the width of the gate.

Other proprietary fence systems will be acceptable if the above criteria are met.

## 1.6 Backfilling of Tanks

All tanks shall be backfilled prior to the installation of any cover, e.g. Slats or slabs. This is to prevent the possibility of the bank beside the tank collapsing under the weight of vehicles delivering and unloading slats or slabs. When slats, slabs or beams are being unloaded, care should be taken to ensure that the vehicle delivering them does not park on the recently backfilled area.

## 2 Emptying of Existing Tank

The existing tank shall be fully emptied prior to the commencement of any work on the extension of the tank. Before anybody enters the tank, the tank shall be tested for the presence of any harmful gases. This test shall include, but not be limited to, testing for hydrogen sulphide (H<sub>2</sub>S), methane (CH<sub>4</sub>), ammonia (NH<sub>3</sub>) and carbon dioxide (CO<sub>2</sub>). If there is any doubt as to the levels of gases present, full breathing apparatus shall be used by anyone entering the tank. Gas testing and breathing apparatus shall only be used by trained, competent personnel.

## 3 Removal of Existing End Wall of Tank

Prior to removal of the existing end wall of the tank, the area for the extended tank shall be excavated. This will give working space for the removal of the existing end wall of the tank. The excavation shall not be made any deeper than is absolutely necessary to ensure minimum disturbance of firm ground. Only after excavating the new portion of the tank should the existing tank cover be removed.

The existing end wall shall be removed by cutting with a concrete saw of suitable size. Hydraulic concrete saws of suitable size are available from specialist contractors. The cut shall be made approximately 200mm inside the end wall of the tank as shown in Figure 1. This will leave a smooth face to enable a good quality joint to be made. The end wall of the tank shall not be removed using any other method than that given above.

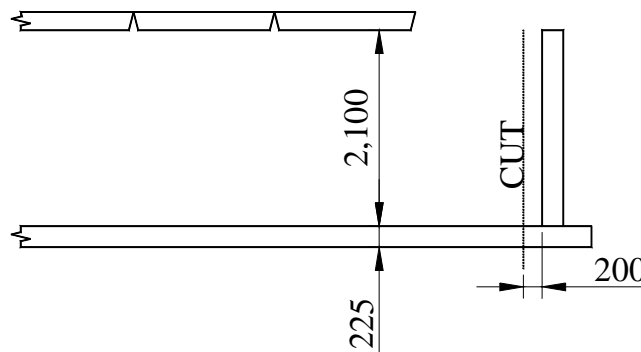
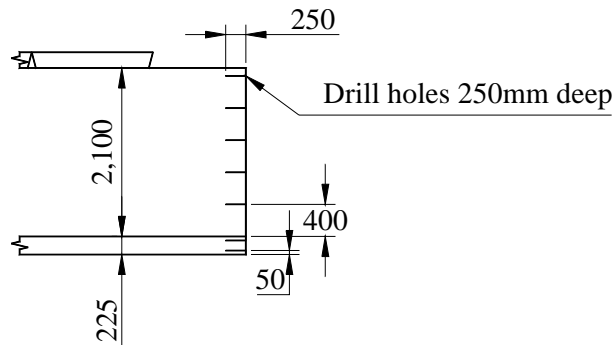

**Figure 1:** Location of cut to remove existing tank end.

## 4 Constructing New Joint

Holes shall be drilled into **both faces** of the tank wall and in the **top and bottom** of the floor at 400mm spacings as shown in Figure 2. The diameter of the holes shall be such that the reinforcing bar to be used, given in Table 1, will fit tightly into place prior to the addition of the fixing mortar. The holes shall be at least 250mm deep. The holes shall be drilled so that there is at least 50mm of cover to the new reinforcing steel. The wall holes shall be drilled as close as possible to the existing horizontal steel in the walls.

Insert new reinforcing steel into both faces of the walls and floor in staggered lengths as given in Table 1 and Figure 3. The size of the reinforcing bar shall be as given in Table 1. The reinforcing shall be fixed in the holes using a proprietary non shrink epoxy mortar or other suitable proprietary bonding agent and left to set for the manufacturers recommended time before being disturbed. The dowels shall be fixed to the tank extension reinforcing bars as per clause 8.1 of S. 123. A water bar shall be attached along the centre line of the walls and floor of the tank joint. The water bar will be of a type suitable for attaching to insitu concrete, normally a flat bonded strip, with an expansion delay coating, such as ‘Supercast SW20’ or ‘Hydrotic CJ Type (Hydrophilic waterbar)’.

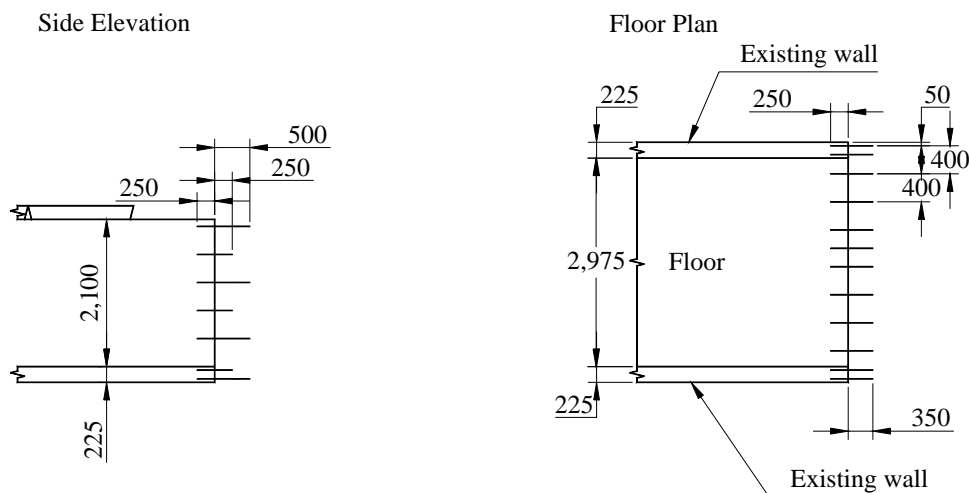

**Figure 2:** Location of drill holes in 2.1m deep tank.

**Table 1:** Size and length of reinforcing bar

Tank Depth (not more than)	Reinforcing dowel diameter	Short bar length	Long bar length	Max. Dowel spacing (225mm wall)	Max dowel spacing (300mm wall)
1.5m	10mm	500mm	750mm	400mm	300mm
1.8m	10mm	500mm	750mm	400mm	300mm
2.1m	12mm	500mm	750mm	400mm	300mm
2.4m	16mm	500mm	750mm	400mm	300mm
2.7m	16mm	750mm	1000mm	400mm	300mm
3.0m	16mm	750mm	1000mm	400mm	300mm

**Note:** The holes drilled shall be of such a size as to ensure the reinforcing bar shall fit tightly in place.



**Figure 3:** Location and lengths of reinforcing dowels

## **5 Tank Extension**

The tank extension shall be constructed and reinforced to the standard as set out in S. 123. Great care shall be taken to ensure that the foundation under the tank extension is well compacted so that it will not settle. The new floor extension shall be reinforced with at least A393 mesh, regardless of length or width

## **6 Tanks Shallower than 1.2 m**

Shallow tanks shall be extended in a similar manner. The only difference being that the dowel spacing shall be reduced to 300mm, and all dowels shall have total length of 500mm.

## **7 Certificates**

The following certificates shall be collected, and given to the Department before grant-aid can be paid:

- (1) "Slat" Certificate
- (2) "Concrete" Certificate
- (3) Precast Unit (where appropriate)
- (4) Certificate of completion to S. 123A – see appendix A.

## **8 Related Department Specifications**

The current edition of the specifications listed below shall also be followed as required:-

- 1) 'S123: Minimum Specification for Bovine Livestock Units and Reinforced Tanks'
- Copies of this and other relevant Department specifications are available on the department website at: [www.agriculture.gov.ie](http://www.agriculture.gov.ie) under farm buildings or by contacting the one of the local offices of the Department of Agriculture and Food.

**Appendix A. –**

Contractors Certificate of Compliance with S. 123A: Minimum Specification for the  
Extension of Concrete Tanks.

To be reproduced on contractors headed paper as per sample given overleaf.

*To Be Completed on Contractors Headed Paper*

**Contractors Certificate of Compliance with S. 123A: Minimum Specification for the Extension of Concrete Tanks.**

*(To be completed by contractor)*

Name of Client: \_\_\_\_\_

Address of client: \_\_\_\_\_  
\_\_\_\_\_  
\_\_\_\_\_  
\_\_\_\_\_

I hereby certify that the concrete tank has been extended in accordance with Specification S123A: Minimum Specification for the Extension of Concrete Tanks.

Name of contractor: \_\_\_\_\_

Address of contractor: \_\_\_\_\_  
\_\_\_\_\_  
\_\_\_\_\_  
\_\_\_\_\_

Signature of person certifying extension: \_\_\_\_\_

Company Stamp of contractor:

