

**AN ROINN TALMHAÍOCHTA, IASCAIGH AGUS BIA
DEPARTMENT OF AGRICULTURE, FISHERIES AND FOOD**

S124 November 2009

MINIMUM SPECIFICATION FOR CALF HOUSING

The receiving of this specification does not imply approval of a grant application. However, if written approval is issued, then this specification becomes part of the contract between the applicant and the Department of Agriculture, Fisheries and Food.

This is a minimum specification. Where the word “SHALL” is used, then that standard (at least) must be followed in grant-aided buildings. Where a procedure is “RECOMMENDED”, this is advice only on good practice.

Note that all references to other Department Specifications are to the current edition of that specification [available on the Department of Agriculture, Fisheries and Food Website (www.agriculture.gov.ie) under Farm buildings]. Similarly, references to Standards are to the current edition of the Irish, British or European Standard, as appropriate.

This specification incorporates all of the requirements in S.I. No. 14 of 2008, European Communities (Welfare of Calves & Pigs) Regulations, 2003. Any building which does not comply with the accommodation, hygiene, and safety clauses of this specification may not be used by law. [Regulations in S.I. No. 14 of 2008 do not apply to holdings with less than 6 calves, or to holdings where calves are kept with their mothers for suckling.]

1. SAFETY

APPLICANT'S RESPONSIBILITY FOR SAFETY

Applicants are reminded that they have a duty under the Safety, Health, and Welfare at Work Act 2005 to provide a safe working environment on the farm, including farm buildings, for all people who may work on that farm. There is a further duty to ensure that any contractor, or person hired to do building work, provides and/or works in a safe environment during construction. It is the farmer's responsibility to provide a construction stage project supervisor.

SAFETY DURING CONSTRUCTION

Farmer/Applicant Responsibility: Certain construction dangers may be encountered in the course of building or conversion work. Neither the Minister or any official of the Department will be in any way liable for any damage, loss or injury to persons, animals or property in the event of any occurrence related to the development and the applicant shall fully indemnify the Minister or any official of the Minister in relation to any such damage, loss or injury howsoever occurring during the development works.

Dangers: If any or all of the work is undertaken by the applicant/farmer he/she should seek competent advice and undertake all temporary work required to ensure the stability of excavations, superstructure, stanchion foundations and wall foundations, also to divert any drains, springs or surface water away from the works, and to guard against possible wind damage, or any other foreseeable risk.

Power lines: Farm buildings shall not be constructed under or nearer than 10m to an overhead power supply. If advice is required, or if power lines need to be diverted, it is the applicant's responsibility to contact, in writing, the local ESB Networks supervisor before construction commences, and then to follow the ESB Networks conditions.

Danger to children: It is the applicant's responsibility to prevent children from playing or spending time in the vicinity of any building work.

2. CONCRETE SPECIFICATION

Concrete shall be to the standard set out in the Department's specification S101 and shall be certified in the same manner.

3. GENERAL

The basic requirements of calf housing are:

- a) Construction which can provide clean, dry, warm and draught-free accommodation without risk of injury to the health of animals and workers.
- b) Design which allows feeding, cleaning, disinfection and general hygiene.
- c) Design which allows a thorough inspection of calves and easy stock management.
- d) Adequate ventilation shall be provided at all times.
- e) Air circulation, dust levels, temperature, relative humidity and gas concentrations must be kept within limits, which are not harmful to the animal.
- f) Adequate unobstructed floor space.
- g) Facilities for storing and handling wastes.
- h) Accommodation for the isolation of sick calves.
- i) Adequate natural and artificial lighting.
- j) Adequate drinking water.
- k) Adequate drainage

4. SITE

The site for calf housing shall be carefully chosen with a view to minimising operational and constructional problems. The site shall preferably be in an open sunny location. It shall be well separated from potential fire hazards and sheltered if possible. It is recommended for disease prevention that housing be physically separated from other livestock housing. As a general guide, farm calf housing facilities should be located not less than 50m from any waterbody in the case of new farmyards, and not less than 10m in the case of extensions/modifications to an existing facility. The minimum distance between calf housing facilities and housing and a public/private water supply source, either surface or ground, shall be 60m. In vulnerable situations this distance shall be increased up to 300m.

Note: Any land drains shall be stopped at least 10m on the upstream side of a site and diverted around to re-connect with the drainage system at least 10m on the downstream side of the storage area.

5. ACCOMMODATION

5.1 Materials

Materials used for the construction of calf accommodation and in particular pens and equipment with which calves may come into contact shall not cause harm or injury to the animals. All parts of the accommodation with which the animals come into contact shall be capable of being thoroughly cleansed and disinfected.

5.1.1 Individual Pens

The width of individual pens shall be sized as follows: the height of the withers from the ground when the calf is standing by the length of the calf from the tip of the nose to the pin bone multiplied by 1.1. Usually, individual pens shall be a minimum of 1.0m wide by 1.5m in length, but 1.7m length is recommended, especially for isolation pens.

Individual pens for calves except those for isolating sick calves shall not have solid walls but shall have perforated walls, which allow the calves to have direct visual and tactile contact.

Note: Regulations (S.I. 14/2008) state that calves more than 8 weeks old may not be kept in individual pens unless a registered veterinary surgeon certifies that it's health or behaviour requires it to be isolated in order to receive treatment (see section 5.1.3 below).

5.1.2 Group Penning

Calves may be kept in single pens, in groups, or in a combination of both. When group penned, the minimum permissible pen floor space per calf weight and age is as follows:

Table 1 - Spacing requirements for calves at different stages of production

<u>Calf Weight</u>	<u>Calf Age(approx)</u>	<u>Space Required</u>
a) <150kg	< 19 weeks	1.5m ² (1.7m ² is recommended).
b) 150kg < 220kg	19 to 32 weeks	1.7m ²
c) > 220kg	> 32 weeks	1.8m ²

However as a general guide a total floor area of 2.3m² per calf (includes feed passage) with a cubic air capacity of about 7m³ per calf should be provided.

For larger herds a double range of pens with a central feeding passage is suitable. The passage shall not be less than 1.2m wide. Movable pen divisions may be used to facilitate different space requirements and cleaning systems.

5.1.3 Isolation Pens

Solid concrete block wall divisions to roof level shall be used where an isolation pen is incorporated in the building. All drainage from isolation pens shall be separated from any other drainage system. Isolation pens shall be provided with adequate daylight, and draught-free ventilation, and a water supply. It is strongly recommended that isolation pens have a separate entrance when being incorporated into a calf house building. See the Department's specification S147 Minimum Specification for Calving Pens, Separation Pens & Isolation Boxes.

6. BUILDING

The superstructure shall conform to current edition of Department's specification S101 – Minimum specifications for the Structure of Agricultural Buildings.

6.1 Roof Cladding Materials

All roof and side cladding materials shall comply with the current edition of S102 and shall be fitted in accordance with manufacturers instructions.

Translucent sheeting shall be provided to at least 10% of roof area except where space sheeting is used. See Clause 7: Ventilation.

6.2 Floors

6.2.1 Concrete Floors

Solid floors shall be laid smooth with a non-slip finish. Floors shall be 125mm concrete on 150mm well compacted and blinded hardcore. Channels in floors shall have a full 150mm thickness of concrete at the sides and under the invert. A damp proof course of 1000 gauge polythene shall be laid on the blinded hardcore. Pen floors shall have a minimum fall of 1:20 to a front drainage channel 75mm x 75mm. The channel shall be located a minimum of 300mm inside the feed barrier as per Figure 1.

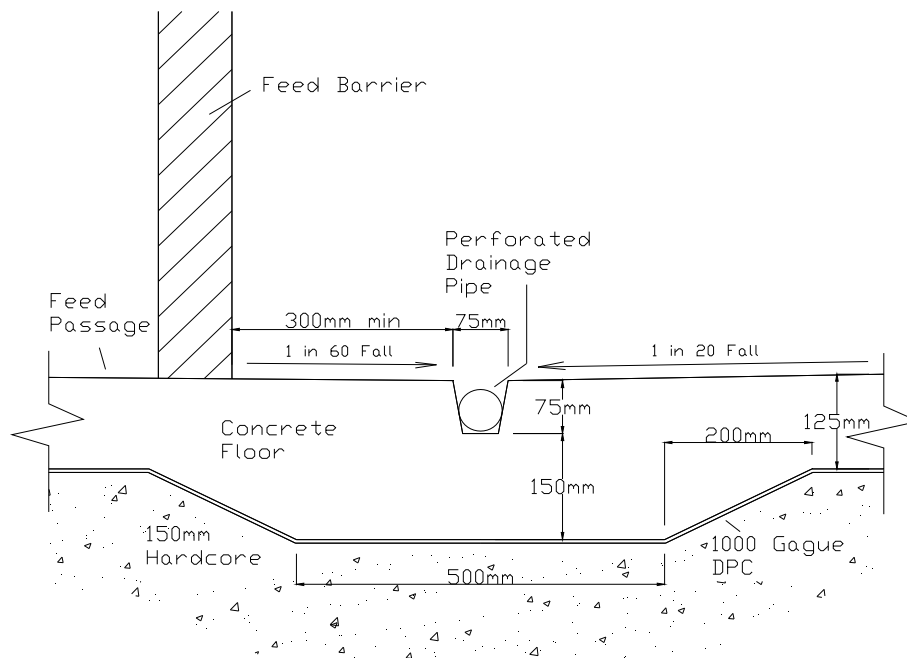

Figure 1 Construction of drainage channel

The feed barrier drainage channel shall have a fall of 1 in 60, which shall run to a suitable storage tank. Please refer to the Department's specification S123 for the construction of storage tanks.

The passage floor in double houses shall have a fall from its central line to the drainage channels inside the feed barrier. These channels shall have a minimum fall of 1:60 to convey effluent and soiled water through a trapped gully to an existing effluent drainage system or to a separate storage tank. For details of floor insulation see 6.2.3.

6.2.2 Slatted Floors

Floors may also be slatted over tanks or channels, using concrete slats or slats of other proprietary systems (e.g. galvanized metal, reinforced plastic, wood etc.) provided the slats conform to the minimum dimensions given in **Error! Reference source not found.**. Note: The beam width dimensions are only applicable to concrete slats. See also clause 6.2.2.1.1

6.2.2.1.1 General

When laid, slats shall comply with the following requirements:-

- 1) Finished slat floor shall be level and free from any rocking movement.
- 2) Be capable of being replaced with minimum disturbance.
- 3) Under no circumstances shall there be internal agitation points within the building. All agitation points shall be external as per the Department's specification S123.

6.2.2.2 Concrete Slats

Concrete slabs and slats over tanks shall be designed and installed as per the Departments specification S.123.

Concrete slats shall be produced in accordance with IS EN 12737: 2004, and all slats produced after 1st July 2011 shall be CE marked and produced in a plant certified by a Notified body (e.g. NSAI or equivalent), to produce slats to IS EN 12737:2004. The concrete slats shall be load tested and be on the accepted calf slat list. The concrete used in the manufacture of the slats shall be produced in a plant audited to I.S. EN 206-1: 2002 by a certified body accepted by The Department of Agriculture, Fisheries & Food (e.g. N.S.A.I., B.S.I., Q.S.R.M.C).

6.2.2.2.1 Requirements for Concrete Slats

1. Be free from any cracks, honeycombing, and chipping of the top corner arises.
2. Have a full bearing of at least 75mm at every point of support.

Beams to support slats shall be precast and sourced from the slat supplier. They shall be designed to ensure that at least the minimum bearing is maintained at all times. Beam size may vary with different length slats and various distances between supports. The beams shall be supported as per the manufacturers instructions.

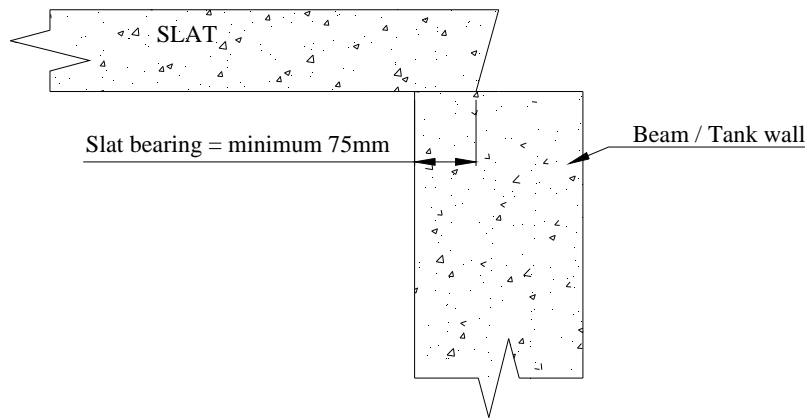

Figure 2: Diagram showing concrete slat bearing.

Table 2- Dimensions for concrete calf slat

	Beam Width (mm)	Gap Width (mm)
Calves	70 – 120	20 - 28

6.2.2.3 Proprietary Plastic Slats

All proprietary plastic slats for grant-aided calf housing shall be selected from the current edition of the Departments list of Accepted Slats for Calf Housing. For all manufacturers wishing to be included on the list please refer to the document “Procedures for inclusion onto Accepted Slat list for Calf Housing” on the Departments website. These slats shall be installed as per the manufacturers instructions.

6.2.2.4 Timber Slats

Timber slatted floors shall be made up in sections to size that can be readily handled, generally not more than 5m² to 6m².

The timber slats shall be at least 50 x 22mm fixed at even spacing of not greater than 28mm with the framing and infill timbers at 600mm centers. Suitable sizes for framing and infill timbers are as follows:-

- Up to 1.6m span - 44 x 100mm.
- Up to 2m span - 44 x 125mm.
- Up to 3m span - 44 x 150mm.

Sections shall have minimum 100mm bearing on support walls and shall be laid parallel to the entry openings to pens.

Note: These slats are only designed for calf weight up to 90kg approx. 8 –12 weeks old.

6.2.2.5 Other Proprietary Slats

All other types of proprietary slats require prior approval by the specialist unit. Manufacturers can find details on approval procedures on the Departments website under

“Procedures for inclusion onto Accepted Slat list for Calf Housing”. These slats shall be installed as per the manufacturers instructions.

6.2.3 Floor Insulation

Where calves are straw-bedded no floor insulation is necessary. Where calves are being housed on concrete floors with no bedding 25mm of expanded polystyrene shall be placed over floor DPC, and also vertically at the junction of the floor with external walls, prior to the placing of concrete floors.

6.3 Walls / Pen Divisions

6.3.1 Mass Concrete Walls

All external mass concrete walls shall be constructed as per the Department’s specification S101.

Mass concrete walls shall have a smooth, blemish free finish and any honeycombing and tie-bar holes shall be filled with an accepted non- shrink proprietary cement mortar.

6.3.2 Block Walls

All external block walls shall be at least 200mm thick and otherwise shall be constructed as per B9 of the specification S101. All internal non-load bearing walls shall be 150mm solid concrete block or reinforced mass concrete. A layer of damp proof course shall be laid at floor level for all solid concrete block walls. Solid concrete block walls shall be rendered internally with two coats, 12mm and 6mm respectively, with 3:1 sand cement rendering with plasticiser or ¼ part lime, to a smooth steel trowel finish. Block walls shall be rendered externally with one coat 12mm thick to a nap or smooth finish.

6.3.3 Pen Divisions

Pen divisions at least 1.2m high, may be fixed or moveable. Tubular steel divisions or concrete block walls plastered to a steel trowel finish are preferred to timber, which can harbour disease. Fixed divisions may be walls or tubular steel bedded in the floor. Movable divisions of tubular steel may be held on posts set in sockets in the floor and by hook and eye bolts in the walls. Alternatively removable tubular steel field gates may be used. For solid divisions coated steel sheeting to the Department’s specification S102 may be fixed to a framework of tubular or box section steel. It is recommended that tubular steel work be galvanised.

Note 1: In long houses, the use of one or more solid pen divisions is recommended to reduce draughts.

Note 2: Individual pens shall not have solid walls separating them from other pens. These pen divisions shall have perforated walls that shall enable tactile and visual contact with other calves. Only in circumstances where the calf is certified by a veterinarian due to health or behaviour the above perforated wall is not required. See isolation pens section 5.1.3 above.

6.3.4 Pen Fronts

Pen fronts shall be movable, afford access to the pen, and provide openings for calves to feed. For single pens and pens for up to 6 calves, the whole front may be hinged as a gate and provided with troughs and/or bucket holders. Where proprietary automatic feeding methods are used pens shall be fitted in accordance with manufacturers instructions. For bucket fed calves the minimum feeding space shall be 350mm per calf.

Note: Calves shall not be tethered, with the exception of group-housed calves, which may be tethered for periods of not more than one hour at the time of feeding milk or milk substitute.

If tethers are fitted they shall not cause injury to the calves, and shall be designed to avoid risk of strangulation or injury. All tethered calves shall be monitored during the feeding period.

6.4 Doors

Doors to central passages shall, where fitted, be sliding, as shall any other door in the building wider than 1.2m. The sliding gear shall be fitted and erected as per manufacturers instructions for the size and weight of door fitted. A sliding door should preferably incorporate a hinged type outward-opening single personnel door with minimum headroom of 2.2m above ground level. Cladding materials for doors shall conform (at least) to the standards specified in the Department's specification S102 - Roof Cladding and Side Cladding.

7. VENTILATION

7.1 Natural Ventilation

Permanent open ventilation shall be provided, as per the Department's specification S101. Providing the correct ventilation is a strict condition of grant-aid, in order to protect animal health and the working life of the structure. Opening/closing windows, or opening/closing half-doors, **shall not be included** in the required inlet/outlet areas given below. Full ventilation shall also be provided in any conversion or extension of existing buildings.

The use of vented cladding is highly recommended as the main source of inlet ventilation for calf houses. It is recommended that vented cladding should also be used at the gable ends of the building. Continuous open ventilation along the sidewall of the building is not recommended as a source of inlet ventilation.

7.2 Artificial Ventilation

Natural ventilation specified above is strongly recommended for buildings, but where an artificial ventilation system is used, provision shall be made for an appropriate back-up system to guarantee sufficient air renewal to preserve the health and well-being of the calves in the event of the failure of the system, and an alarm system, independent of the mains electricity supply, shall be provided to warn the owner or person in charge of the animals in the event of a breakdown or in the event of fire. The alarm system shall be tested at least once a month and maintained in proper working order.

8. LIGHTING AND ELECTRICAL INSTALLATIONS

A minimum lighting level of 50-lux shall be provided. All lighting and electrical works shall be carried out and certified as specified in the Department's specification S101.

Accommodation shall be well lit for a period of at least 8 continuous hours each day either through natural or artificial means. Artificial lighting shall be mounted so as not to cause discomfort to the calves. An adequate source of light shall be available to enable the calves to be properly inspected at any time.

Power points shall be provided to the food store and at suitable locations when the use of mechanical feeders and power washers is anticipated.

Note: Calves shall not be kept permanently in darkness.

9. FOOD STORE

Where the calf house is for more than 20 calves it is recommended that a food store/food preparation area be provided with a minimum floor space of 0.2m² per calf. Where a food store is constructed it shall have its own air space and shall have a separate outside door, incorporating a secure lockable arrangement for storing chemical and veterinary products. It is recommended that a sink with hot and cold water supply be provided in this area.

10. WATER SUPPLY

10.1 Cold Water

A cold water supply shall be provided within the calf house. Drinkers shall be provided to each group pen or two adjacent pens. Drinkers may be fitted on dividing gates in a manner to facilitate dismantling and removal with the gates to allow for mechanical cleaning. Piping should be protected from animals and frost. To reduce fouling of lying areas, drinkers shall be located close to the feeding passage.

10.2 Hot Water

It is recommended that a hot water supply be provided by means of an electrical water heater or a conveniently located boiler. This supply can be used especially in the cleaning out of the automatic feeders and the mixing of milk replacer. Suitable equipment shall be installed as directed using the appropriately qualified persons.

It is also recommended that a wash basin / sink be installed along with a paper towel dispenser.

11. PEN FITTINGS

Feeding and watering equipment for calves shall be designed, constructed, placed and maintained so that contamination of feed and water is minimised.

Equipment and fittings shall be designed and maintained in such a way as to minimise, as far as is practicable, the exposure of the calves to spills of feed or water, or to faeces and urine.

12. WASTE DISPOSAL

All effluent / solid farmyard manure and soiled water shall be stored in compliance with the Nitrates Directive S.I.101: 2009. All solid farmyard manure storage facilities shall be constructed in accordance with Department of Agriculture, Fisheries & Food specification S108. Where effluent tanks are being used they shall be in accordance with the relevant Department's specifications.

12.1 Isolation Pen Waste

Solid waste and effluent from isolation pens shall be collected separately from that of the main herd and disposed of separately on to ungrazed land. See the Department's specification S147 for further details with regards to waste from isolation pens.

13. PROTECTION OF STRUCTURAL STEELWORK

For protection of structural steelwork refer to Department of Agriculture, Fisheries & Food specification S101.

All non-structural steelwork that is ungalvanised shall be given a primer coat and 2 coats of long life lead-free paint. Any exposed timberwork shall be given a primer coat, 2 undercoats and a hardgloss finish coat of lead-free paint.

14. CERTIFICATES

The following certificates shall be given to the Department before grant-aid will be paid:

1. "Concrete" Certificate
2. Certificate of Protection of Structural Steel
3. "Electrical" Certificate
4. Concrete Slat Certificate