

AQUACULTURE - LICENSING UNDER
FISHERIES (AMENDMENT) ACT, 1997 and
FORESHORE ACT, 1933

SHELLFISH AND FINFISH

Aquaculture and Foreshore Licence Application Form

Important Note

Section 4 of the Fisheries and Foreshore (Amendment) Act, 1998 (No. 54) prohibits any person making an application on or after 10 December 1998 for an Aquaculture Licence from commencing aquaculture operations until duly licensed under the Fisheries (Amendment) Act, 1997 (No. 23), and provides that a breach of that prohibition will cause the application to fail.

**Aquaculture & Foreshore Management Division
Department of Agriculture, Fisheries & Food
Clogheen
Clonakilty, Co. Cork**

Fax: (023) 8821782

**AQUACULTURE AND FORESHORE LICENSING APPLICATION FORM, for purposes
of FISHERIES (AMENDMENT) ACT, 1997 and FORESHORE ACT, 1933**

Accompanying Guidance Notes should be read before completing this form.

Note: Details provided in Parts 1 and 2 will be made available for public inspection.
Details provided in Part 3 are confidential and are not for public disclosure.

For Office Use
Application Ref. No. T10/284
Date of receipt, (Dept. Stamp):

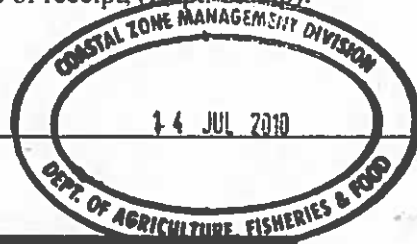

USE BLOCK CAPITALS IN BLACK INK

PART 1: PRELIMINARY DETAILS

Name(s) of Applicant(s) in full:	
1.A	Michael Kilbane
1.B	
Address(es) of Applicant(s) in full:	
1.A	1.B
Dooagh	
Achill	
Co Mayo	
Tel: 098 43969 086 2200165 Fax:098 43867	Tel: Fax:

<u>I.C TYPE OF APPLICATION</u>	Insert X in relevant box
Indicate the relevant type of application:	
-(i) Aquaculture Licence	<input checked="" type="checkbox"/>
-(ii) Trial Licence	<input type="checkbox"/>
-(iii) Review of Aquaculture Licence	<input type="checkbox"/>
-(iv) Renewal of Aquaculture Licence	<input type="checkbox"/>
-(v) Foreshore Licence	<input checked="" type="checkbox"/>
(This Application Form is valid for each type of application.)	

Achill Sound

Pacific Oysters

<u>I.D TYPE OF AQUACULTURE</u>	
Indicate the relevant type of application:	
-(i) Land-based	<input type="checkbox"/>
-(ii) Marine-based	<input checked="" type="checkbox"/>
-Shellfish	
(iii) - extensive	<input type="checkbox"/>
(iv) - intensive	<input checked="" type="checkbox"/>
-(v) Finfish	<input type="checkbox"/>

1.E DOCUMENTS ENCLOSED WITH THIS APPLICATION

The following documents are enclosed with this application:

- (1) - Ordnance Survey Map (Scale of 1: 10,560, ie, a six inch map) *OBLIGATORY*
- (2) - British Admiralty Chart (largest available scale)
- (3) - Decision of planning authority under Planning Acts
- (4) - Copy of licence under Section 4 of Local Government (Water Pollution) Act, 1977
- (5) - Environmental Impact Statement
- (6) - Drawing of the structures to be used and/or the layout of the farm *OBLIGATORY*
- (7) - Water Quality Analysis Report (required for Land-based sites only)
- (8) - Application Fee *OBLIGATORY*
- (9) - Other (specify): _____

PART 2: DETAILS RELATING TO PROPOSED AQUACULTURE PROJECT

2.A Employment, Qualifications, Experience, Etc.

(i) Details of Applicant's qualifications and experience in aquaculture: _____

I have been farming oysters since 1993 but have been in trial production since 1981. I have attended courses and workshops on oyster production over the years . Also , I have been to France twice with BIM to see production methods and make contact with other producers there and meet purchasers.

(ii) Other relevant experience (courses attended, etc): _____

_____ I have attended courses and seminars run by the Marine Institute and BIM . I have been to France to see production methods and meet buyers

(iii) Details of projected employment creation during first four years of proposed development: _____

_____ At present I have 3 part-time employees , however , with increased production to 40 tonnes I will need 2 fulltime and 2 part-time employees _____

(iv) Projected employment (number of persons):

Year 1:	3 part-time	Year 2:	4 part-time	Year 3:	2 fulltime + 1 part-time	Year 4:	2 fulltime + 1 part-time
---------	-------------	---------	-------------	---------	--------------------------	---------	--------------------------

2.B Aquaculture Site Details

Indicate type of site:

- (i) Land-based
- (ii) Marine-based

<input type="checkbox"/>
<input checked="" type="checkbox"/>

2.C Land-Based Site

(To be completed if appropriate)

(i) State species to be farmed: _____

(ii) State proposed system of culture e.g., pond, raceway, circular tank or other method: _____

(iii) Full address of proposed site including Townland and County: _____

(iv) Tonnage to be produced:

Year 1:		Year 2:		Year 3:		Year 4:	
---------	--	---------	--	---------	--	---------	--

(v) Proposed source of stock: _____

(vi) Name of river(s) supplying site with water: _____

(vii) Estimate drought flow in gallons per minute: _____

(viii) Is there a fall of 1.5 metres in the water level at this site or can this be obtained by damming the river without giving rise to flooding of your own or neighbour's land upstream of the site? _____

(ix) Area of proposed site (hectares): _____

(x) Details of services available on the site e.g., main road access, electricity: _____

(xi) Are there at present any possible sources of pollution upstream of the site, e.g. discharge from sewerage plant, farmyard, sheep dip facility, silage effluent, quarry, sandpit or factory? YES NO

(xii) If yes, supply details: _____

Land-based Site (continued)

2.D The following must be supplied:

- (i) Sketch of the layout of the site in relation to the river(s), road(s) and buildings;
- (ii) Water quality Analysis Report, which should be drawn up in accordance with the parameters set out in Annex C of the Guidance Notes.

2.E The following conditions must be met in order to allow for consideration of licensing of land-based aquaculture:

- (i) the buildings and equipment must be put in place to the Department's satisfaction; and
- (ii) the operation must comply with Local Authority requirements.

2.F Marine-based Site(s)

(To be completed if appropriate)

Location - (i) Bay: Achill Sound

- (ii) County: Mayo

(iii) OS Map No: Mayo 65

(iv) Size (hectares): 4 hectares

(v) Species (to be specified): crassostre gigas

-Aquatic Plant(s)

-Any form of aquatic food suitable for the nutrition of fish

(vi) Method of culture (e.g., nets, ropes, tanks, trestles, etc.) oyster bags on steel trestles and cages

(vii) Drawings of structures to be used in method of culture should be enclosed. ✓

(viii) If cages or tanks are proposed, state:

- (a) Number: Holding cages

- (b) Type and shape: Reinforcement mesh in frame

- (c) Cubic Capacity: 2.5 meters

- (d) Depth: 1.2m

(ix) Proposed specific site locations (with reasons): This area was previously licensed and there is currently

oyster production opposite on the other side of the channel

(x) Describe proposed purification facilities to be used, where appropriate: _____

The oysters are sold in bulk to France and are not for domestic consumption

Marine-based Site(s) (continued)

2.G Give details of any special requirements relating to the health of the proposed project and the wider matters of public health and safety: _____

_____ I have a Fish Health Management Plan Approved by the Marine instate in place and I
_____ participate in a Risk Based Surveillance Scheme and have an appropriate biosecurity regime.

2.H Tonnage to be produced:

<u>Species</u> (To state)	<u>Year 1:</u>	<u>Year 2:</u>	<u>Year 3:</u>	<u>Year 4:</u>
<u>Gigas (cunrrent)</u>	<u>15</u>	<u>15</u>	<u>15</u>	<u>15</u>
<u>Gigas (new area)</u>	<u>0</u>	<u>5</u>	<u>15</u>	<u>30</u>
_____	_____	_____	_____	_____
_____	_____	_____	_____	_____
_____	_____	_____	_____	_____

2.I Reasons for selection of site(s): _____

_____ The area has been designated by the Minister as an Bivalve production area. _____

_____ Oysters are grown nearby on the other side of the channel _____

_____ I produce oysters on a site not far away in the same channel _____

**Note: The proposed access route to the site(s) from public road across tidal foreshore area
Must be indicated on the OS map accompanying the application.**

2.J Environmental Impact Statement (EIS).

A copy of an EIS, if required, should be enclosed with the application. The EIS should contain the information specified in Annex B of the Guidance Notes.

2.K Trial Licence.

(To be completed if appropriate)

Describe experimental or investigative nature of the proposed project: _____

[Use separate page if required – to be signed and dated]

B. MARKETING (continued)

3. Will the product be processed or packaged?

YES

NO

4. If yes, give details:

I/We hereby declare the information provided in Parts 1, 2 and 3 above to be true to the best of my/our knowledge. I/We enclose an application fee* of € 95.23 with this application.

Signature(s) of Applicant(s):

Michael Kilbane

Dooagh Achill

Co Mayo

Date:

13 July 2010

*Preferred method of payment is by cheque or bank draft. The fee should be made payable to the Department of Agriculture, Fisheries and Food.

This form should be forwarded, with the required documents and application fee, to:

Aquaculture Licensing
Aquaculture & Foreshore Management Division
Clogheen
Clonakilty,
Co. Cork

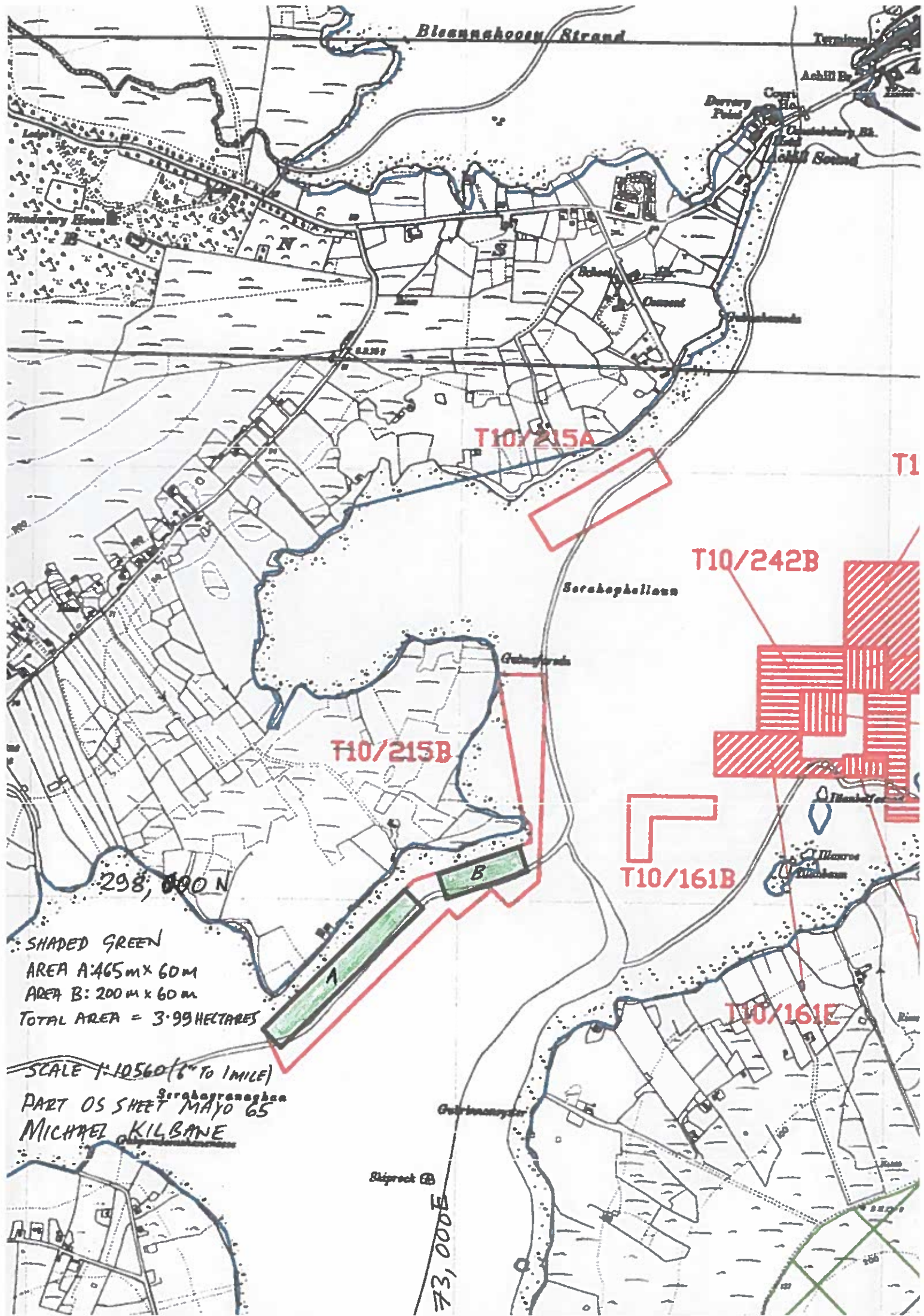

Blennahoon Strand

Achill Br.
Court Hall
Quintenary Bl.
Achill Sound

T10/215A

T1

T10/242B

Searobhallaun

T10/215B

Gubaghrada

T10/161B

298, 000 N

SHADED GREEN
 AREA A: 465m x 60m
 AREA B: 200m x 60m
 TOTAL AREA = 3.99 HECTARES

T10/161E

SCALE 1:10560 (6" TO 1 MILE)
 PART OF SHEET MAYO 65
 MICHAEL KILBANE

Gubraghrada

Sliproad

73, 000 E

MICHAEL G. KILBANE
DOOAGH
ACHILL,
CO MAYO

STEEL TRESSEL

LENGTH 3.0M
WIDTH 0.9M
HEIGHT 0.6M

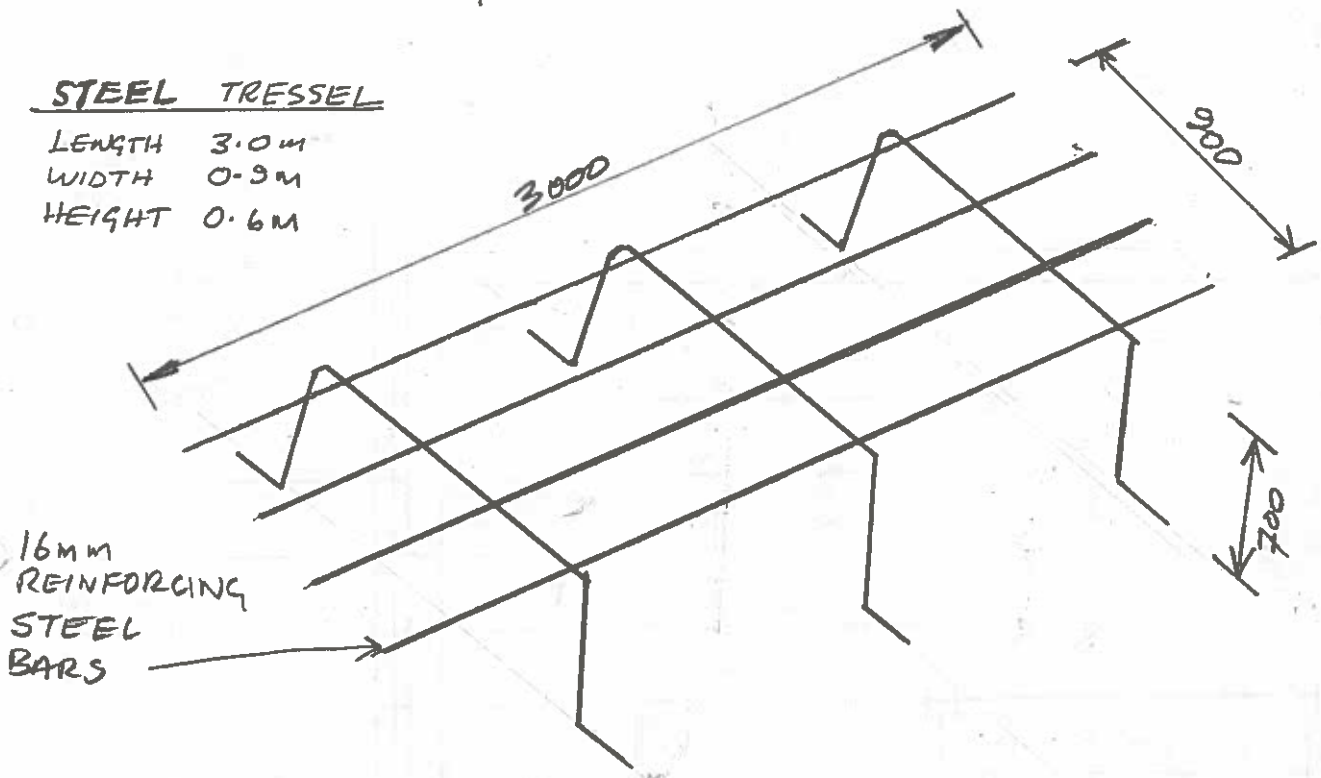

SEED CAGE

LENGTH 2.0M
WIDTH 0.5M
HEIGHT 0.7M

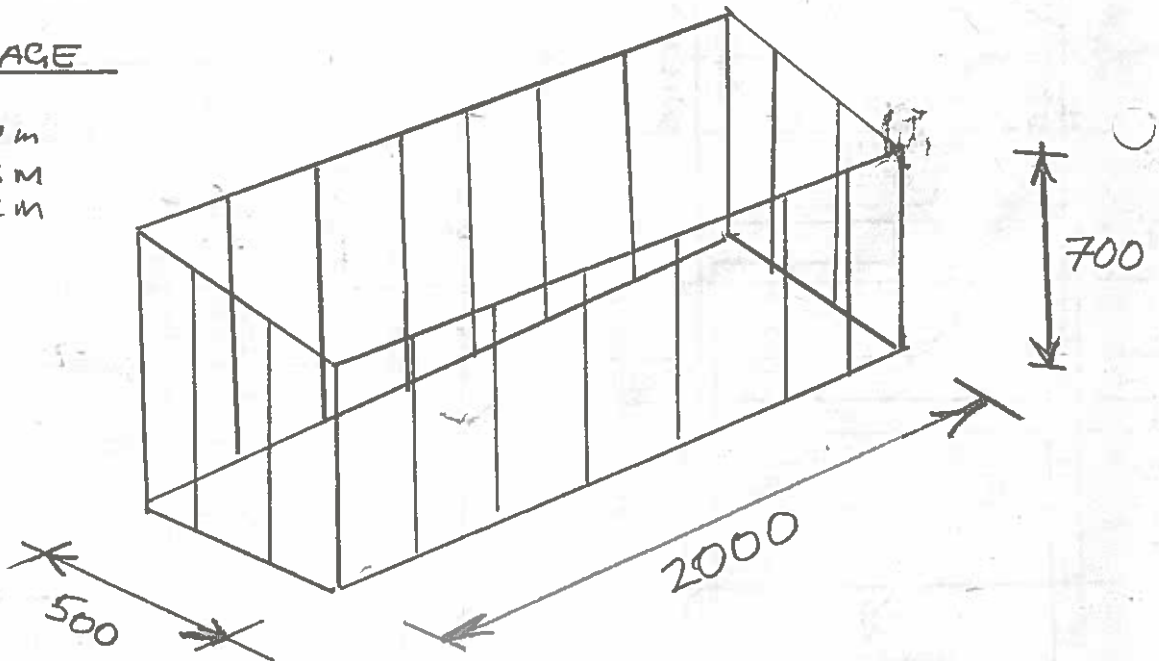

CRADLE

3 cradles
 3 sheets A333
 3 lengths of $\phi 20$

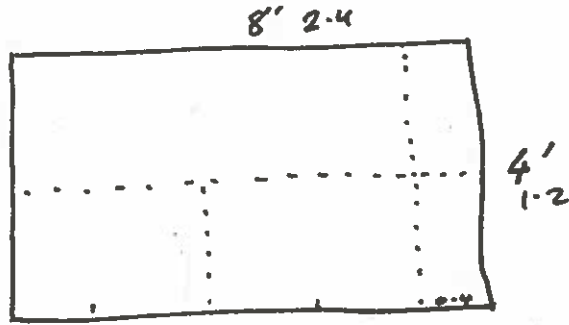

16mm
 REINFORCING
 STEEL BARS

29m.
 4 x 6m.

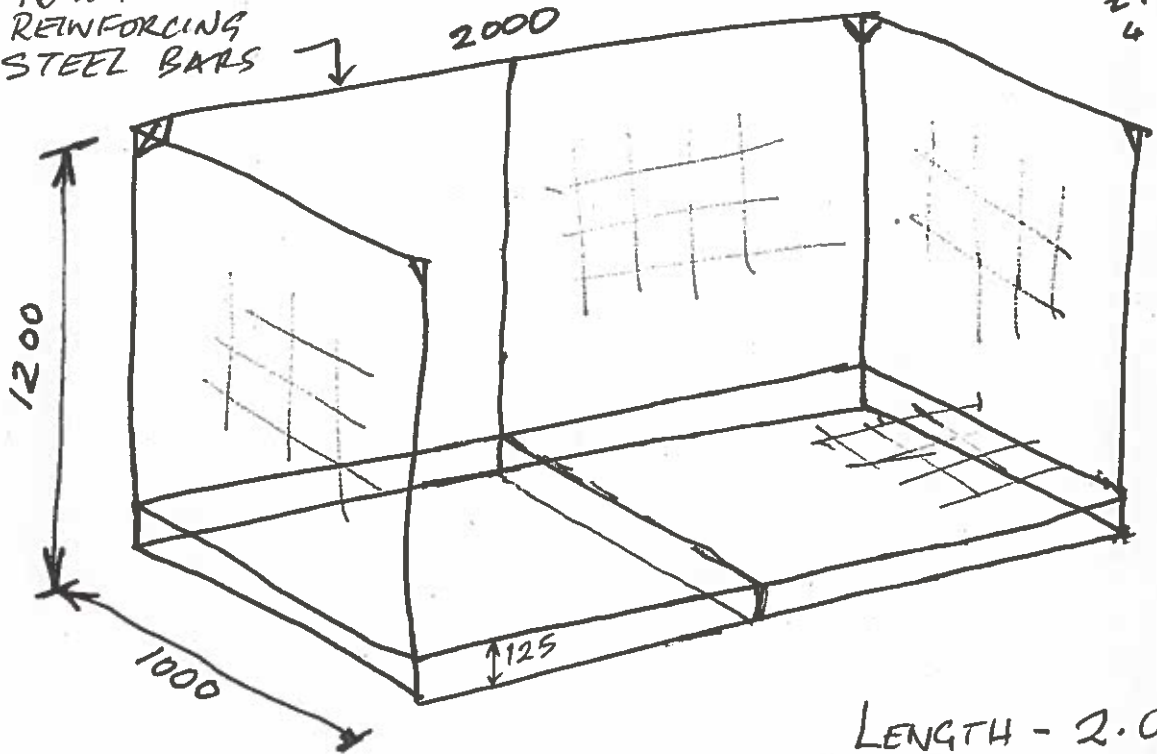

STEEL
 MESH
 SIDES + BOTTOM

LENGTH - 2.0m
 WIDTH - 1.0m
 HEIGHT - 1.2m

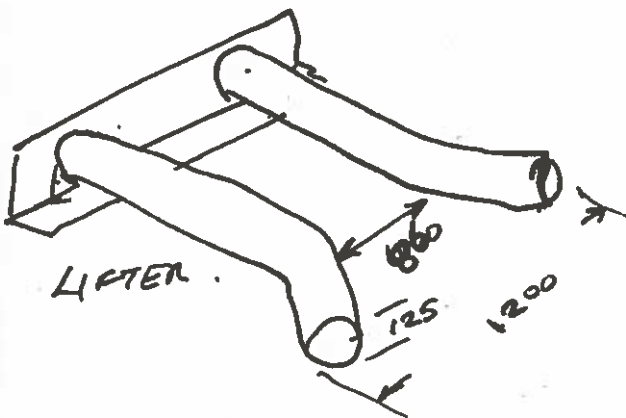

STORAGE CRADLE
 FOR
 MICHAEL KILBANE
 DOOAGH
 ACHILL Co MAYO.



10 March 2011

Karen Gill
Deirdre Fitzpatrick
Bernie McDonnell
Brigetta Lovett

Re: Site No. T10/284A -B

Please see attached:

1. Gridded map showing site outlined red.
2. BA Chart showing site outlined red.
3. List of Co-ordinates of site.

Further information requested.

1. Does the site overlap other sites..... OVERLAPS T10/215 (LAPSED 2002)
2. Is site in or adjacent to Natura 2000 area ... NO
3. Is sites in or adjacent to Shellfish Waters Designated area... NO
4. Is site in or adjacent to an Oyster/Mussel Fishery Order area... NO
5. Is site in or adjacent to a naturally occurring Mussel/Oyster bed in this area.....
REFER TO REGIONAL ENGINEER.

Michael Doyle
John Weldon
Engineering Division









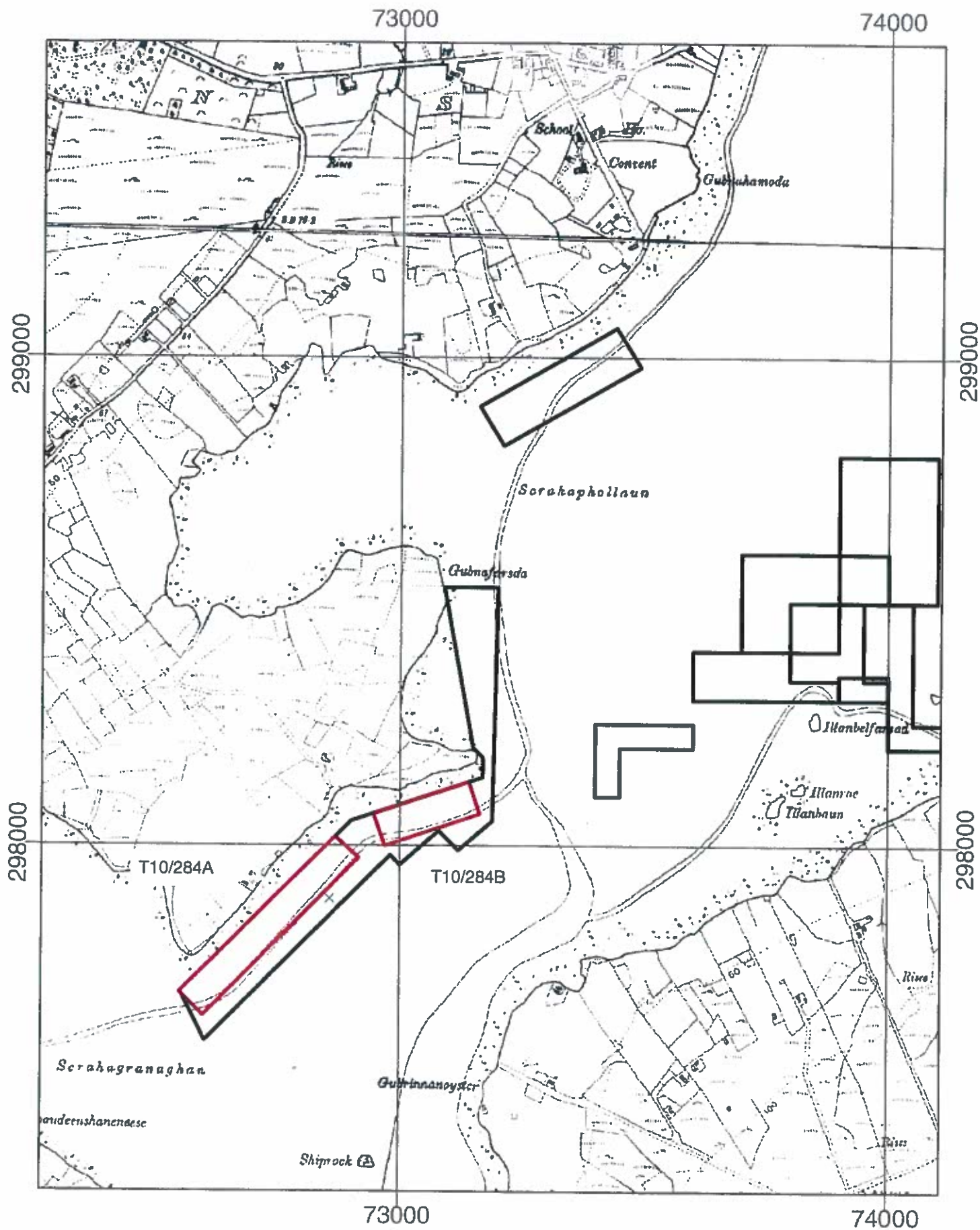

An Roinn Taispeánann,
Insealgh agus Tis
Rannán na hInsealghóiríochta
Linn Chéil (Keshbeg)
Balla Átha Cliath 2.

Tel: (01) 6992006
Fax: (01) 6623215

Department of Agriculture, Fisheries and Food
Engineering Division
Lisson Lane
Dublin 2.

E-mail: info@agriculture.gov.ie
Web site: www.agriculture.gov.ie



- Aqua Culture Sites**
- Site_Status**
-  Application
 -  Application Lapsed
 -  Application Refused
 -  Application Renewal
 -  Application Withdrawn
 -  License Altered
 -  License Revoked
 -  License Surrendered
 -  Licensed
 -  Unknown
 -  Unlicensed

1:10,000

Printed under License No:6155
 From The Ordnance Survey.
 Copyright Government of Ireland 2008.
 Unauthorised Reproduction is not permitted



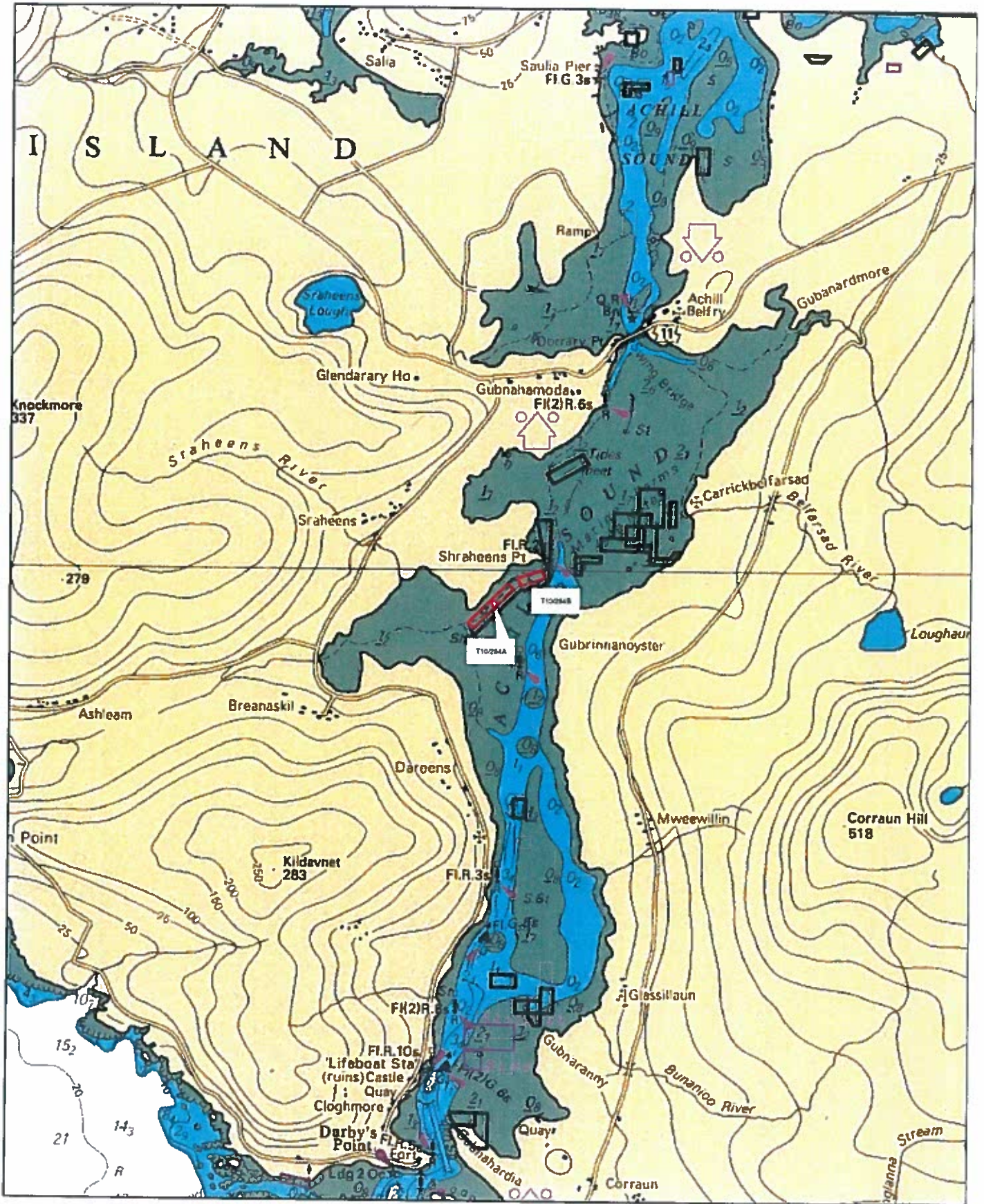

1:40,000

- Aqua Culture Sites**
- | Site Status | Description |
|--------------------|-----------------------|
| [Red box] | Application |
| [Pink box] | Application Lapsed |
| [Purple box] | Application Refused |
| [Blue box] | Application Renewal |
| [Light blue box] | Application Withdrawn |
| [Light green box] | License Issued |
| [Light yellow box] | License Revoked |
| [Light orange box] | License Surrendered |
| [Light purple box] | Licensed |
| [Light blue box] | Unknown |
| [Light green box] | Unlicensed |

Part of Admiralty Chart No. 2667
Not to be used for Navigation.

1 NO. SITE AT Achill Sound CO.Mayo

Co-ordinates & Area

Site T10/284A (3.012 Ha)

The area seaward of the high water mark and enclosed by a line drawn from Irish National Grid Reference point

072548, 297698 to Irish National Grid Reference point
072867, 298017 to Irish National Grid Reference point
072916, 297974 to Irish National Grid Reference point
072597, 297651 to the first mentioned point.

1 NO. SITE AT Achill Sound CO.Mayo

Co-ordinates & Area

Site T10/284B (1.432 Ha)

The area seaward of the high water mark and enclosed by a line drawn from Irish National Grid Reference point

072969, 297998 to Irish National Grid Reference point
072946, 298064 to Irish National Grid Reference point
073142, 298130 to Irish National Grid Reference point
073164, 298064 to the first mentioned point.